

336000 HYDRONIC AND STEAM UTILITIES

Table of Contents

1.0 - GENERAL	2
A: TOPICS COVERED IN THIS STANDARD:	2
B: SUMMARY	2
C: SCOPE	2
D: SYSTEM INFORMATION	2
2.0 - TIE-IN TO CAMPUS DISTRIBUTION	4
A: COORDINATION	4
3.0 - DESIGN STANDARDS	6
A: GENERAL	6
B: PIPING SYSTEMS	11
C: PIPE MATERIALS	12
D: STEAM AND CONDENSATE SYSTEMS	13
E: HDPE PIPING SYSTEMS	16
F: FUSION JOINING	16
G: FUSION JOINING TESTING	17
H: VALVES	18
I: PRESSURE GAGES, NON-BOILER DRUM	18
J: SPECIALTIES	18
K: PIPING INSULATION	19
L: PIPING SUPPORTS	20
M: PIPING INSTALLATION	21
N: PIPE TESTING	21
O: PIPE CLEANING	22
P: VALVE TAGS AND IDENTIFICATION	22
Q: MANHOLES	23

1.0 - GENERAL

A: TOPICS COVERED IN THIS STANDARD:

- 1: GENERAL
- 2: TIE-IN TO CAMPUS
- 3: DESIGN STANDARDS

B: SUMMARY

- 1: The contents of this document shall be used as design standards only. It is the responsibility of the consultant to ensure specifications and related details and drawings conform to all applicable minimum requirements of safety and regulatory standards. The standards presented here are not a substitute for due diligence on the part of all parties providing design or construction services. Accordingly, no liability will be assumed on the part of the University for any damages arising from the use of this document. No language contained in this document shall be used unaltered as specifications or copied verbatim for use as such.

C: SCOPE

- 1: The information found in this document shall be considered applicable to all distribution and transmission lines, including those in tunnels, direct buried piping, manhole interiors, and distribution lines located in building interiors up to the building's utility connection point. Utility connections to buildings shall be considered the limits of this document's guidance, including building's isolation valves and/or meter. The contents of this document do not apply to the HVAC system or HVAC piping in building interiors. Information and requirements for building HVAC systems can be found in documents under Division 23 – Heating Ventilation, and Air Conditioning (HVAC). Design drawings and specifications shall include details of connections to mechanical room piping. Isolation valves are to be implemented in all building connections such that service interruptions can be limited to individual buildings without affecting service to adjacent structures. Requirements for metering of steam and chilled water utilities can be found in Section 253000 - Integrated Automation Instrumentation & Terminal Devices.

D: SYSTEM INFORMATION

- 1: Steam
 - 1.D.1.a. The Duke Energy Cogeneration Plant is responsible for the production of steam for the campus, while the steam distribution network is the responsibility of the University and its employees. Steam is distributed at 70 psig and 320 degrees F. Steam service is utilized for a variety of purposes including building space heating and reheating, hot water heating, and laboratory processes.
- 2: Chilled Water

- 1.D.2.a. The chilled water system for the University is composed of 9 campus chilled water plants totaling over 42,000 tons of cooling capacity. The design of the central district system allows for various plants to be interconnected to support the required chilled water demand and to provide redundancy for the campus buildings. Chilled water service is distributed in a closed loop system, leaving the plants at 45 degrees F and returning at 55 degrees F. Chilled water is utilized for building interior space cooling. Piping with a diameter greater than or equal to 12" nominal pipe size will be considered transmission lines. Piping with a diameter less than 12" nominal pipe size will be considered distribution lines.
- 1.D.2.b. Existing and proposed buildings are guaranteed a positive differential pressure at the building's interface with distribution utility piping outside the building. All pressure losses inside the building shall be accommodated by the buildings mechanical systems and the Engineer shall include this analysis and design in the appropriate construction documents.

3: Coordination

- 1.D.3.a. Design Workshop and Pre-construction Meetings for Utilities:
 - 1.D.3.a.i: Prior to design, the Engineer shall schedule a workshop with the Planning, Design and Construction (PD&C) and Facilities Services Utility and Energy Services (FS-UES) for coordination to discuss the project scope, identify proposed utility tie-in locations, discuss pipe sizes, and discuss any potential manhole rehabilitation requirements. Refer to Typical Manhole Rehab Detail STM-7. Specifications shall require the Contractor to schedule a pre-construction meeting attended by the University including Facilities Services including Facilities Services Operations (FS-OPS), the Engineer, and the Contractor prior to start work date to discuss existing conditions in the project area and share project-specific information regarding lead-times for outage requests. The Contractor and Engineer shall obtain locations of known utilities in the area prior to scheduling the pre-construction meeting. Existing utility locations shall be investigated in concert with FS-UES personnel.
 - 1.D.3.a.ii: The Contractor shall coordinate with FS-UES to provide access to all exposed new and existing utility piping, conduit, duct bank, valves etc. uncovered or installed during construction. FS-UES personnel or a proxy shall use GPS equipment to capture the location of all exposed utilities of any service before Contractor begins backfilling or otherwise obstructs access to exposed utilities.

2.0 - TIE-IN TO CAMPUS DISTRIBUTION

A: COORDINATION

- 1: All connections to existing steam and chilled water systems must be supervised, scheduled, and coordinated with Facilities Services Utilities and Energy Services (FS-UES).
- 2: Ambient Conditions
 - 2.A.2.a. Connections to the system and all other work requiring interruptions of service should be made during favorable weather conditions when ambient temperature is below 70 degrees Fahrenheit for chilled water outages, or above 55 degrees for steam outages.
- 3: Outage Requirements
 - 2.A.3.a. A schedule of work to be performed during the outage must accompany any shutdown request, subject to approval by FS-UES. Multiple crews may be necessary to complete work in the time allotted for utility shutdown. Connections will be permitted only when FS-UES has approved a requested outage.
 - 2.A.3.b. In the event that a building's steam or chilled water service must be temporarily interrupted, a minimum notice of 7 calendar days' must be provided to individual building occupants. Outages affecting multiple buildings will require 14 calendar days' notice. Buildings operated by Health Science Center, Department of Housing, and IFAS require additional advance notification of between 14 and 30 calendar days depending on the scope of the outage. All service interruptions shall be coordinated with Facilities Services (FS-UES and FS-OPS). Interrupting hydronic service to certain buildings may require the Contractor to provide temporary boilers or chillers and related support equipment. Examples of buildings that may require such considerations include housing, research facilities, dining halls or other student food services. Service interruptions to these buildings will likely require additional coordination between FS and other departments and such buildings should be identified early in the design process.
 - 2.A.3.c. All isolation valves to be utilized during shutdown must be tested and confirmed operational prior to any tie-in work. Any shutdown of steam and chilled water utilities is to be performed by FS (UES and/or FS). Meters must be installed before new connections to steam and chilled water service are operational.
- 4: Tie-In to Mains
 - 2.A.4.a. Lines with a diameter greater than or equal to 12" nominal pipe size are considered transmission mains. Transmission mains require special considerations before permitting additional connections, and FS-UES reserves the right to deny requests for connections to these lines. Any permissible connections to transmission mains shall be accomplished with full size tee connections. If reducing tees are to be considered, special

approval must be granted by FS-UES. No hot or wet tap connections are permitted on transmission mains without prior approval by FS-UES for location, method, and execution.

- 2.A.4.b. Taps must be performed by qualified personnel with adequate equipment and experience. Freezing chilled water lines is an acceptable method for executing wet taps. For steam systems, the thermal stress analysis shall consider connecting into an already hot system.
- 2.A.4.c. Any temporary piping, fittings, valves, insulation, and pipe supports used during construction must meet temperature and pressure ratings of the system on which they are installed. They may not be required to meet all other normal specifications of permanent piping and equipment per the discretion of the Engineer. The Contractor is responsible for maintaining all temporary equipment. No temporary equipment can remain connected to the system at the time of final completion.

3.0 - DESIGN STANDARDS

A: GENERAL

- 1: All hydronic piping systems shall be coordinated and integrated with respect to existing utilities and their surroundings. The Engineer shall supply design drawings for all piping systems demonstrating compliance with ASME B31.1 at a minimum. Drawings shall show location and arrangement of all proposed utilities work, and the Engineer shall identify to FS-UES where any of the requirements in this document cannot be satisfied due to existing spatial restrictions. Pipe size, expansion, frictional losses, and utility service shall be taken into consideration when planning location of piping layout, including elevation. The Contract Documents shall state that piping shall not be installed in a location other than indicated in drawings without prior approval from the FS (UES and OPS) and the Engineer.
- 2: Alignment
 - 3.A.2.a. Early in the process of designing utility routing and layout, the Engineer shall obtain a full subsurface utility survey of the proposed construction area. During design, FS is available to assist the surveyor in identifying existing utilities. The University assumes no responsibility or liability with respect to the accuracy of the information provided. The Engineer shall investigate the possibility of installing proposed new utilities in known abandoned utility corridors as a means of avoiding unexpected conditions.
 - 3.A.2.b. All calculations showing thermal stress compliance with ASME B31.1 shall be submitted for approval prior to design completion. Calculations shall be signed by a licensed professional engineer in the State of Florida. The specifications shall require the piping system manufacturer also perform these calculations and include them with the final piping layout system submittal. The Engineer shall minimize the number of joints and couplings used.
 - 3.A.2.c. All ASME B31.1 analyses shall be performed using the conservative method and no expansion stresses shall exceed 90% of allowable – this applies to Engineer and manufacturer’s calculations and shall be included in the direct buried system specifications. Anchors shall be clearly identified on the design documents.
 - 3.A.2.d. Branch connections for systems with linear expansion joints shall occur at the anchor locations, not on the pipe moving into the expansion joint. Upon construction completion, all anchors and expansion loops shall be captured into the GIS model by FS-UES or its proxy.
 - 3.A.2.e. When expansion loops are used for thermal stress analysis, they must be explicitly stated on the drawings so that the Contractor is aware of their purpose. Provide dimensions on the drawing or specifically designate the expansion loop. Indicate all guide locations. Locate all pipe supports for vertical expansion loops since they can greatly affect the loop performance. Use a thermal stress analysis program to determine expansion loop sizes as opposed to charts or tables that do not take into consideration all the factors of a design.

- 3.A.2.f. The minimum depth of direct buried steam and chilled water systems shall be 3 feet. Except for landscaped areas, minimum cover requirements may be reduced with approval from FS-UES. Where 3 feet of cover is not available, the Engineer shall design additional insulation and/or additional structural protection against vertical loading.
- 3.A.2.g. Trees and large foliage shall not be planted within 10 feet of steam/condensate utility lines with joints. There are numerous large oak trees on the University's campus. Mature oak trees have a shallow and large spreading root system and will require greater clearance than listed above. The Engineer shall investigate the project area for such conflicts and communicate all concerns to FS-UES early in the design process.
- 3.A.2.h. Piping shall be installed either at right-angles or parallel to building walls. System designs calling for diagonal alignments must have explicit approval by FS_UES.
- 3: Steam
- 3.A.3.a. The high temperatures involved in steam and condensate piping require greater offsets from other heat-sensitive utilities such as HDPE/PVC piping systems, electrical, and all carrier piping or conduits that have temperature restrictions. A minimum 2 feet of horizontal clearance and an absolute minimum of 2 feet of vertical clearance (with a preference for vertical clearance of 4 feet or more where possible) shall be provided between steam and condensate pipes and other heat-sensitive utilities. If and where FS-UES allows Pitt-wrap systems to be installed, minimum horizontal clearance requirements shall be 5 feet.
- 3.A.3.b. If proper clearance cannot be achieved, the Engineer shall design an acceptable buffer of waterproof insulation on the heat-sensitive utility. The design of this insulation buffer shall be demonstrated to provide sufficient thermal protection to remove the possibility of negative consequences to the sensitive utility. Even in instances where proper clearance is available, care should be taken to design crossings with other utilities to occur using perpendicular, right-angle alignments wherever possible.
- 3.A.3.c. The University has a strong preference for expansion loops over expansion joints. If expansion joints are used for linear expansion, the Contractor must use laser alignment to align piping. Laser alignment shall be used during system fabrication and all subsequent adjustments to supports, anchors, guides, and expansion joints. Laser alignment equipment shall remain on piping systems until an Owner's representative witnesses proof of alignment.
- 3.A.3.d. Groups of steam and condensate piping shall be installed in parallel, leaving sufficient clearance for insulation installation, valve servicing, and thermal expansion.
- 3.A.3.e. All direct buried steam piping shall be pitched/sloped at a minimum of 0.5% in the direction of steam flow.
- 3.A.3.e.i: The preferred installation is that the pipe be sloped in the direction of steam flow. Any deviation from this shall be approved in writing from Facilities

Services. If allowed the pipe shall slope at a minimum of 1.0% when the pipe is sloped opposite the direction of steam flow.

- 3.A.3.e.ii: Gravity return lines (condensate) must run downhill – no high points shall be installed to naturally trap the return.
 - 3.A.3.f. Manhole spacing and steam trap placement is preferred to be 300 feet apart with consideration to elevation changes and maximum distance for traps. Provide steam trap stations and dirt legs on both sides of isolation valves where there is a potential that steam could be back-fed from another source. There are many instances on campus where there are redundant feeds. If there is any question, ask FS-UES.
 - 3.A.3.g. Isolation valves shall be provided on steam systems no more than every 1,000 feet or every fourth manhole. This allows steam piping to be started up in segments. At each isolation valve, provide a warm-up valve across the isolation valve per Detail STM-14. Provide drip legs and steam trap stations on both sides of the isolation valve if steam can originate from both sides. If there is any doubt where steam can flow from, ask FS-UES.
 - 3.A.3.h. Manholes shall be located at low points in the system and include steam traps. Steam traps in manholes shall be installed a minimum of 2 feet above the bottom of the manhole floor. All condensate traps shall be installed a sufficient height above the bottom of the drip leg as to prevent dirt from entering the trap line.
 - 3.A.3.i. A dead leg is created in the steam system when main line isolation valves are closed. A drip leg and trap station shall be installed on the side of such valves creating the low point. If an is valve is located on a run fed from both sides it may be the case that the valve is the low point for the system on both sides of the valve, requiring a drip leg and trap assembly to be installed on both sides of the valve. A manual drain shall be installed on both side of the valve in such situations.
- 4: Chilled Water
- 3.A.4.a. Chilled water supply and return lines shall be installed in parallel, leaving sufficient distance between pipes for valve installation, future maintenance, and thermal movement.
 - 3.A.4.b. Chilled water piping shall be installed with minimum horizontal clearance of 2 feet, and a minimum of 1 feet vertical clearance with respect to existing utilities. Refer to “Steam and Condensate” above for offsets to steam and condensate piping for new and existing uncompromised direct buried piping systems as judged by FS–UES. Review with FS at the design workshop. Additional offset is required with respect to compromised steam and condensate utilities as judged by FS-UES: HPDE chilled water piping shall be installed with at least 10 feet of horizontal clearance and an absolute minimum 24 inches vertical clearance (with a preference for vertical clearance of 4 feet or more where possible).
 - 3.A.4.c. No low-points or high-points shall be created between manholes allowing for complete drainage and venting in the manholes. Valves with adjacent drain

ports shall be included to facilitate pipe drainage. Locations of vents and drains are subject to approval by the Engineer and FS-UES.

- 3.A.4.d. All piping within chilled water system manholes shall be carbon steel. When transitioning from carbon steel to HDPE, the transition fitting shall be located outside of the manhole.
- 3.A.4.e. HDPE piping experiences much greater thermal contraction than does carbon steel used in distribution. The specifications shall warn the Contractor of thermal movements of the pipe with respect to daily ambient temperature changes and sunlight when making final connections.

5: Design Criteria

- 3.A.5.a. Pipe size shall maintain required building connection pressure, and in no case shall exceed specified maximum velocities or local pressure drops stated herein.
- 3.A.5.b. Pipe size reduction should only be accomplished through the use of fabricated reducing fittings, and only when appropriate to system parameters.
- 3.A.5.c. "Design" pressures and temperatures are the highest temperatures and pressures the system will experience, exclusive of potential water hammer. All components in the piping system shall satisfy design conditions. Design conditions are the peak conditions for the ASME B31.1 thermal expansion analysis.
- 3.A.5.d. "Operating" pressures and temperatures describe conditions of the utilities as they leave the generation facilities or downstream of pressure reducing stations. Actual system pressure available at building connections will be lower due to pressure drop throughout the distribution system. Pressure gages at building connections shall not be used to establish available pressure, as these can fluctuate seasonally. FS-UES will provide minimum available pressures at building connections.

6: Steam

- 3.A.6.a. For service to existing buildings that are being renovated or added to or upgraded, FS-UES shall share historical metering data to the Engineer when available. If not available, the Engineer shall estimate the building steam demand prior to the changes. During the initial design workshop, the Engineer shall provide FS-UES with calculated maximum steam demand for any changes and renovations to the existing system. These findings should be summarized on the construction drawings.
- 3.A.6.b. The Engineer shall calculate pipe sizes per the requirements in this document. FS-UES may require these pipe sizes to increase based on potential future growth. Half-sizes (2 ½", 3 ½", etc.) are to be avoided where possible. Main isolation valves shall match the pipe size.
- 3.A.6.c. Pipe movement due to thermal expansion shall be accounted for through the use of expansion loops, Z's, & L's. Expansion joints should be avoided for applications other than walk-through utility tunnels.

3.A.6.d. For the purposes of calculating piping stresses, anchor loading, etc., the Engineer shall use the criteria established below for “Design Conditions”. Every component of the steam and condensate system from anchors to expansion loops, expansion joints, fittings, valves, trap bodies, etc. shall be capable of continuous operation at these “Design” conditions. (NOTE: Trap orifice performance shall be selected based on the “Operating” condition, not the “Design” condition, but the body shall be rated for “Design” conditions. Orifice selection is covered in the “Steam Condensate Traps” section of this document).

3.A.6.e. High Pressure Steam: Designated as “HPS” or “250S,” located in main N/S steam tunnel connecting Rabon and Weil chiller plants.

Conditions:

Operating: 210 PSIG at 450 deg. F

Design: 270 PSIG at 510 deg. F

Maximum Velocity:

For 4” piping and lower: Shall be 8,000 FT/MIN.

For piping larger than 4”: Shall be 12,000 FT/MIN.

Maximum pressure drop shall be 0.5 PSID / 100 FT.

3.A.6.f. Medium Pressure Steam: Designated as “MPS” or “70S,” which is the majority of campus distribution steam piping.

Conditions:

Operating: Max of 70 PSIG at 335 deg. F (expected during summer)

Min of 60 PSIG at 307 deg F (expected during winter)

Design: 90 PSIG at 474 deg. F

Maximum Velocity:

For 4” piping and lower: Shall be 4,000 FT/MIN.

For piping larger than 4”: Shall be 8,000 FT/MIN.

Maximum pressure drop shall be 0.5 PSID / 100 FT.

7: Condensate Return

3.A.7.a. Condensate return consists of both trap returns from the distribution system and pumped returns from the buildings and distribution system. In some cases in the existing system, trap condensate is connected directly to the pumped condensate return line. Trap Returns

3.A.7.b. Trap returns must conform to the same design and operating temperatures and pressures as the steam system to which they are attached. If trap return piping from systems of different pressures is joined together, all such return piping shall be designed to the specifications of the higher pressure system.

3.A.7.c. High Pressure Condensate: Designated as “HPC” or “250C,” located in main N/S steam tunnel connecting Rabon and Weil chiller plants. The design and operating conditions match that specified above for HPS.

Maximum Velocity: Shall be 4,000 FT/MIN

Maximum pressure drop shall be 1 PSID / 100 FT

3.A.7.d. Medium Pressure Condensate: Designated as “MPC” or “70C,” majority of campus distribution steam piping. The design and operating conditions match that specified above for MPS.

Maximum Velocity: Shall be 4,000 FT/MIN
Maximum pressure drop shall be 1 PSID / 100 FT

3.A.7.e. Pumped Returns: Shall be labeled as “PC.”

Conditions:
Operating: 30 PSIG at 160 deg. F (Note actual can be lower due to gravity return system in many areas.)

3.A.7.f. Design: 75 PSIG at 250 deg. F

Maximum Velocity: Shall be 10 FT/SEC
Maximum pressure drop shall be 1 PSID / 100 FT.

8: Chilled Water

3.A.8.a. The University’s chilled water system is divided into districts which dictate design parameters. The Engineer shall request information about the relevant district from FS-UES in order to determine demand, temperature change at building connections, pressure availability, and any other requirement for chilled water systems. The results are to be submitted to FS-UES for approval.

3.A.8.b. Maximum velocity shall be 4 FT/SEC for 2” pipe and lower and 8 FT/SEC for 2-1/2” pipe and larger.

3.A.8.c. Maximum pressure drop shall be 4 FT HD / 100 FT and may be more restrictive to satisfy overall system pressure drop.

3.A.8.d. Chilled water piping shall be labeled “CHWS” (Chilled Water Supply) and “CHWR” (Chilled Water Return).

3.A.8.e. Campus chilled water piping systems consist of both HDPE and ferrous piping. Different properties of these materials dictate different approaches to sizing and involve different standards. For HDPE piping, all references to pipe size shall be made to DIPS (ductile iron pipe size standard) which is the inside pipe diameter.

3.A.8.f. Ambient installation temperatures should be assumed to be no lower than 70 deg. F for the purposes of thermal stress analysis. Supply temperatures shall be approximately 42 deg. F in the summer.

B: PIPING SYSTEMS

1: Piping shall be as specified for each particular system. Victaulic, fiberglass, and FRP piping are not acceptable.

2: All piping, fittings, and specialties including expansion joints, strainers, etc. shall be manufactured, fabricated, and assembled in the United States or Canada, or they shall be by an ISO 9001 registered corporation. No piping, fittings, or specialties manufactured, fabricated, and/or assembled in China, Taiwan, or India are permitted on

any project including those companies registered with ISO 9001 without prior authorization from FS-UES.

C: PIPE MATERIALS

- 1: All pipe specifications shall follow the PIPING INDEX. This table is for all aboveground systems (in manholes and tunnels) and all piping systems inside of double wall conduits for direct buried system.
- 2: Gaskets for steam and condensate systems shall be spirally wound, Type 316L stainless steel with non-asbestos filler material and carbon steel outer ring. Gaskets shall be 1/8 inch thick and conform to the flange face on which they are used. Provide Flexitallic Style CG with Flexite Super Filler or approved equal.
- 3: Gaskets for chilled water systems shall be non-asbestos, compressed sheet, nitrile binder with a rated maximum operating temperature and pressure of 700 degrees F and 1200 psi, respectively. Gaskets shall be 1/8 inch thick and conform to the flange face on which they are used. Provide gaskets from Sepco, Sur-Seal, or Flexitallic.
- 4: Direct Buried Piping Conduit Systems

3.C.4.a. Common Requirements

The system supplier's representative shall be responsible for directing the installation and testing of the conduit system, including training the installing contractor, overseeing the installation process, and reviewing manufacturer's installation instructions with the Contractor and FS inspectors. Submit the factory representative's resume for approval by the FS. Where the manufacturer's warranty requires the factory representative to be on site during all phases of construction, that factory representative shall be assigned for the duration of the project. The manufacturer's warranty dictates the level of factory representative on-site required and shall be adhered to strictly. The Contractor is responsible for compliance with manufacturer's instructions. FS and the Engineer may inspect the installation as clarified below but neither party has responsibility for the installation or quality control measures for the warranty. It shall be certified in writing by the supplier that the factory representative is technically qualified and has a minimum of 5 years' experience in the design and/or inspection of the systems. Irrespective of warranty requirements which may be more or less stringent than below, inspections will be performed as follows:

- 3.C.4.a.i: Inspection and unloading: At a minimum, the factory representative shall witness the first unloading procedure. At this first trip, the factory representative shall review the manufacturer's instructions with FS-UES and FS-OPS, Contractor, and Engineer.
- 3.C.4.a.ii: Inspection of trench prior to laying of conduit: At a minimum, the factory representative shall inspect the first set up. At this first trip, the factory representative shall review the manufacturer's instructions with the FS-UES, Contractor, and Engineer. FS will perform inspections with spot inspections by the Engineer after the initial inspection and meeting with the factory representative.

- 3.C.4.a.iii: Inspection of expansion loops: If 100% on-site factory representative is not required by warranty, FS-UES and the Engineer may perform inspections.
 - 3.C.4.a.iv: Inspection of joining of system: At a minimum, the factory representative shall witness the first joint closure procedure. If 100% on-site is not required for warranty, FS-UES may witness all subsequent pipe joining work.
 - 3.C.4.a.v: Hydrostatic Testing (piping): Regardless of manufacturer's warranty requirements for the on-site factory representative, FS-UES and FS-OPS will witness.
 - 3.C.4.a.vi: Air test (conduit): Regardless of manufacturer's warranty requirements for the on-site factory representative, FS-UES and FS-OPS will witness.
 - 3.C.4.a.vii: Repair of any patchwork: At a minimum, the factory representative shall inspect the first repair. If 100% on-site is not required for warranty, FS-UES may perform inspections with spot inspections by the Engineer.
 - 3.C.4.a.viii: Back filling of conduit sections: If 100% on-site factory representative is not required by warranty, FS-UES and Engineer may perform inspections.
- 3.C.4.b. The Piping Installation Contractor shall not perform any of the above stated work in the absence of the Piping Supplier's representative. Where 100% on-site attendance is not required by the Piping Supplier's representative, the Piping Installation Contractor shall not perform any of the above stated work in the absence of FS Utilities inspector.
- 3.C.4.c. Backfill: A 6 inch layer of Archer sand shall be placed and tamped in the trench to provide uniform bedding for the conduit. The entire trench shall be evenly backfilled with a similar material as the bedding in 6 inch compacted layers to a minimum height of 6 inches above the top of the insulated piping system. Bedding and backfill materials shall be as approved by the designer and manufacturer. Note that the composition of the backfill and the compaction of the backfill are extremely important due to possibility of settling and having the link seals and/or conduit system being crushed. Designers must perform due diligence to verify existing soil conditions and provide a design that minimizes settling.

D: STEAM AND CONDENSATE SYSTEMS

- 1: All underground direct buried steam and condensate lines shall be Class A testable, drainable and dryable. The system supplier shall have fabricated systems of the composition described herein for at least three years. All straight sections, fittings, anchors, and other accessories shall be factory prefabricated to job dimensions and designed to minimize the number of field welds. Each system layout shall be computer analyzed by the piping system manufacturer to determine the stresses on the carrier pipe and anticipated thermal movement of the service pipe. The system design shall be in strict conformance with ASME B31.1. The pre-approved conduit system shall include all piping and components to a point as designated on the drawings inside the building, tunnel, or manhole wall. Manufacturers shall be Perma-Pipe (Multi-Therm 750) or Thermacor (Duo-Therm 505) or Rovanco (Insul 800 ELITE).
- 2: The Contractor performing the work shall be responsible for the installation of the pre-approved system and all other components of the underground steam and condensate conduit systems, including the piping equipment in the manholes and buildings. This

responsibility shall include all site work and purchase of the pre-approved system from the system supplier.

- 3: Systems with condensate lines 6 inches and smaller, shall have the trap return and pumped condensate piping contained in a single outer conduit pipe.
- 4: Sub-Assemblies: Gland seals, end seals, and anchors shall be designed by the system manufacturer and factory prefabricated to prevent the ingress of moisture into the system. Gland seals shall be used when thermal expansion is carried through the manhole wall as when an expansion joint is located inside the manhole. When an anchor is direct buried outside of the manhole, end seals shall be used. Make sure end seals and gland seals are called out on the drawings. All sub-assemblies shall be designed to allow for complete draining and drying of the conduit system. Refer to Detail MH-8.
- 5: Insulation shall be Pyrogel XTE per the Piping Insulation Thickness Chart.
- 6: Outer Conduit: The steel conduit casing shall be airtight, pressure testable, smooth wall welded steel conduit. The steel conduit shall withstand H-20 loading with a minimum of 24 inches of cover.
- 7: Outer Conduit Insulation and Jacket: Conduit insulation shall be a minimum of 1 inch thick factory applied polyurethane foam, meeting ASTM C591. The outer jacket shall be either:
 - 3.D.7.a. Fiberglass (FRP) and filament wound directly onto the urethane foam insulation, with a minimum thickness of 0.160 inches for 6 inch and above service pipes and a minimum 0.120 inches for service pipes below 6 inches. Fiberglass field enclosures matching the thickness of the outer jacket shall be used to complete the installation closures. No shrink wrap type will be allowed for closure joints.
 - 3.D.7.b. High Density Polyethylene (HDPE) jacket with a minimum wall thickness of 0.175 inches. No shrink wrap type will be allowed for closure joints. Apply two additional heat shrinkable HDPE field joint closures overlapping the ends of the first field joint closure to provide a layering joint.
- 8: Field Joints: Insulate, seal, and protect all field joints in accordance with the manufacturer's written instructions and utilizing pipe manufacturer's procedures and field joint kits consisting of insulation, coatings and wrapping materials.
 - 3.D.8.a. Hot Water Systems - Reserved
 - 3.D.8.b. Chilled Water Systems
- 9: Pre-Fabricated Carbon Steel Carrier Pipe Based System
 - 3.D.9.a. The complete underground direct buried chilled water distribution piping system shall include all required components such as carrier pipes, fittings, anchors, pipe supports, and insulation. The underground distribution piping systems shall not include valve manholes and the piping and equipment inside the manholes. The underground distribution piping systems shall include all piping and components to a point 12 inches inside the building,

tunnel walls, or manhole walls. The underground piping distribution system shall be rated for 250 PSIG at fluid temperatures up to 140 degrees Fahrenheit. Each underground piping system shall be pre-engineered by the piping system manufacturer. All straight pipe sections, fittings, anchors, and other accessories shall be provided as required by the underground piping system manufacturer. The underground piping system shall be designed in accordance with the ASME B31.1. System shall be carbon steel pipe with fiberglass or HDPE jacketed. Manufacturers shall be Perma-Pipe (Polytherm or Xtru-Therm) or Thermacor (Ferro-Therm) or Rovanco (Steel System).

- 3.D.9.b. The Contractor performing the work shall be responsible for the installation of the piping system and all other components of the underground conduit system, including the manholes and the piping equipment in the manholes. This responsibility shall include all site work and purchase of the piping system from the system supplier.
 - 3.D.9.c. Protective Jacket: Conduit surfaces, inside and outside, shall be cleaned and made free of all loose debris. Protective jacket shall be:
 - 3.D.9.d. Fiberglass (FRP), filament wound directly onto the urethane foam insulation with thickness of 0.160 inches for 6 inch and above service pipes and 0.120 inches for service pipes below 6 inches. Fiberglass field enclosures matching the thickness of the outer jacket shall be used to complete the installation closures. No shrink wrap type will be allowed for closure joints.
 - 3.D.9.e. High Density Polyethylene (HDPE) jackets with a minimum wall thickness of 0.150 inches. A pressure testable electric-fusion process or heat shrinkable (recommended by the manufacturer) HDPE field joint closures equal to or greater in thickness to the outer jacket shall be used to complete the installation closure. No shrink wrap type will be allowed for closure joints. Apply two additional heat shrinkable HDPE field joint closures overlapping the ends of the first field joint closure to provide a layering joint.
- 10: Insulation: Polyurethane Foam insulation, meeting ASTM C591, shall satisfy the Piping Insulation Thickness Chart.
- 11: A written certification from the underground distribution piping system manufacturer verifying that the conduit system contains no voids in the insulation prior to shipment to the job site shall be required. All insulation shall be factory tested for voids prior to application of the protective jacket by infrared inspection over the entire length or x-ray over the entire length.
- 12: Field Joints: Insulate, seal, and protect all field joints in accordance with the manufacturer's written instructions and utilizing pipe manufacturer's procedures and field joint kits consisting of insulation, coatings and wrapping materials.
- 13: Field Insulated/Erected System: Provide PITT WRAP CW Plus jacketing system by Pittsburgh Corning which is a 50 mil thick self-sealing, polymer modified bituminous compound reinforced with a glass fabric and a 1 mil aluminum top film and release paper backing. Install per manufacturer's directions.

E: HDPE PIPING SYSTEMS

- 1: Provide polyethylene pressure pipe manufactured from PE4710 high density polyethylene meeting AWWA C906 and ASTM F714 standards, ductile iron pipe standard (DIPS), Polyethylene (PE) Plastic Pipe (SDR-PR) Based on Outside Diameter or ASTM D3035, Polyethylene (PE) Plastic Pipe (DR-PR) Based on Controlled Outside Diameter. Resin shall meet the requirements of ASTM 3350. HDPE piping shall be rated for 200 psi (DR 11). Fabricated PE Fittings shall have the full rating of the HDPE pipe.
- 2: High Density Polyethylene joints shall be butt-fusion welded and field insulated. All HDPE elbows shall be long radius sectionalized.
- 3: Polyethylene Flange Adapters: Flange adapters shall be made with sufficient through-bore length to be clamped in a butt fusion joining machine without the use of a stub-end holder. The sealing surface of the flange adapter shall be machined with a series of small v-shaped grooves to provide gasketless sealing, or to restrain the gasket against blow-out.
- 4: Back-up Rings and Flange Bolts: Flange adapters shall be fitted with lap joint flanges pressure rated equal to or greater than the mating pipe. The lap joint flange bore shall be chamfered or radiused to provide clearance to the flange adapter radius. Flange bolts and nuts shall be Grade 2 or higher. Bolt pattern for flanges shall be per ANSI B16.5. Back up rings shall be carbon steel. Washers shall be Belville washers.
- 5: Polyethylene Mechanical Joint Adapters: NSF/ANSI 61 mechanical joint (MJ) adapters shall be made with sufficient through-bore length to be clamped in a butt fusion joining machine without the use of a stub-end holder. MJ adapter shall be pressure rated equal to or greater than the mating pipe. Provide stainless steel internal stiffener ring.
- 6: Mechanical Joint: Provide rubber gasket, ductile iron backing ring and all necessary hardware to firmly connect HDPE mechanical joint adapter fitting to ductile iron mechanical joint valve connection.

F: FUSION JOINING

- 1: Butt Fusion Joining - Make joints between plain end pipes and fittings by butt fusion using only procedures that are recommended by the pipe and fitting Manufacturer and ASTM F2620.
 - 3.F.1.a. Ensure that persons making butt fusion joints are certified according to the standards and have proven experience to make fusion welds following Manufacturer's recommended procedures.
 - 3.F.1.b. Maintain records of trained personnel, and certify that training was received not more than 12 months before commencing construction.
 - 3.F.1.c. External and internal beads resulting from butt fusion joining shall not be removed.
 - 3.F.1.d. All fusion joining shall be recorded, reviewed and downloaded to a central database via Datalogger. Datalog records shall be submitted for all pipe fusion joints daily (within 24 hours of fusion joining).

- 3.F.1.e. Use caution to protect the exposed butt ends of pipes from exposure to oils, greases, or hydrocarbons. Any pipe exposed to hydrocarbons of any type shall be cut-out and removed prior to butt fusion.

2: FLANGE JOINT CONNECTION JOINING

- 3.F.2.a. Polyethylene pipe and fittings may be joined to other materials by means of flanged connections (flange adapters, transition fittings and back-up rings) designed for joining polyethylene pipe to another material. Some type of flange adapter and back up rings shall be used and installed in accordance to the piping's manufacturer. In no case shall flange connections be permitted in areas that will be direct buried and backfilled.
- 3.F.2.b. Install flange connections in accordance with the manufacturer's recommended procedure and Plastic Pipe Institute (PPI) TN-38 "Bolt Torque for Polyethylene Flanged Joints". Center and align flange faces to each other before assembling and tightening bolts. Do not use the flange bolts to draw the flanges into alignment. Lubricate bolt threads, and fit Belleville washers under the flange nuts. Tighten bolts evenly according to the tightening pattern and torque step recommendations of the Manufacturer and PPI TN-38. At least four hours after initial assembly, re-tighten flange connections following the tightening pattern and torque step recommendations of the Manufacturer and PPI TN-38.

3: MECHANICAL JOINT CONNECTION JOINING

- 3.F.3.a. Connect polyethylene pipe using mechanical joints where indicated on Drawings. Mechanical joint adapter shall be fusion bonded to the HDPE pipe, and installed with all associated gaskets, stiffeners and hardware.

G: FUSION JOINING TESTING

- 1: Butt Fusion Testing: On the first day butt fusions are to be made for each pipe size, the first fusion shall be a trial fusion. After the trial fusion is allowed to cool completely, cut out fusion test straps and test per ASTM F3183. Do not commence butt fusion of pipe to be installed until a trial fusion has passed the test. Tests shall be witnessed and approved by the A/E and the technical assistant provided by the pipe manufacturer or fusion equipment provider.
- 2: During the initial trial fusion and all subsequent fusions, a Data Logger shall be used to monitor the fusion process to record the necessary critical parameters critical to the fusion process. Upon a successful trial fusion as tested by the bend back test strap, all subsequent butt fusions shall be recorded using the Data Logger and shall match the condition of the initial successful and approved trial fusion. Provided the conditions recorded on the Data Logger match the conditions of the trial fusion, no additional bent strap tests will be required.
- 3: The technical assistant provided by the pipe supplier shall be onsite for the first full day of fusing. Perform all fusion joints in the presence of the Owner or A/E as directed. Record the temperature and corresponding time for each fusion joint.

- 4: Hydrostatic Pressure Testing: Pressure test HDPE pipes in accordance with ASTM F2164, "Standard Practice for Field Leak Testing of Polyethylene (PE) Pressure Piping Systems Using Hydrostatic Pressure". Due to the shrink/swell nature of the HDPE piping, performing this test can take many hours (as long as a full day affair). Provide means for air to be removed from the piping during hydrostatic testing.

H: VALVES

1: General

- 3.H.1.a. Direct buried valves (used for CHWS and CHWR) shall be protected from water via Visqueen and shall be AWWA C509, resilient seated, ductile-iron body and bonnet, non-rising bronze stem, 250-psi working pressure, with a 2-inch square operating nut which shall turn counter clockwise to open, one flanged, and one mechanical joint ends.
- 3.H.1.b. Cast iron box having top section and cover with lettering "CHILLED WATER" bottom section with base of size to fit over valve and barrel approximately 5-1/4 inches in diameter, and screw adjustable cast iron extension of length required for depth of bury of valve. Covers shall be powder-coated blue with color RAL5024. Provide #6 Base Adaptor by Adaptor, Inc.
- 3.H.1.c. Refer to the Piping Index for where the valves are specified and refer to the Valve Chart for the valve specification.

I: PRESSURE GAGES, NON-BOILER DRUM

1: Construction

- 3.I.1.a. Type: Type 316 stainless steel with bottom stem mounted connection.
- 3.I.1.b. Case: Polypropylene case, turret style, durable safety glass, direct mounting style. Diameter shall be 4-1/2 inch.
- 3.I.1.c. Connector and Wetted Materials: Stainless steel with 1/2 inch male NPT.
- 3.I.1.d. Scale: High visibility (Hi-Vis) dial with fluorescent yellow backgrounds, orange pointers, and permanently etched black markings.
- 3.I.1.e. Range: Units shall appear in PSIG units.
 - 3.I.1.e.i: 70S: 0-150 PSIG
 - 3.I.1.e.ii: 250S: 0-300 PSIG
 - 3.I.1.e.iii: CHWS/CHWR: 0-200 PSIG
- 3.I.1.f. Accuracy: Per ASME B40.100, accuracy Grade A.

- 2: Acceptable Manufacturers: Reotemp or approved equal.

J: SPECIALTIES

1: Steam Traps

- 3.J.1.a. Refer to Detail STM-15 for typical piping details for steam trap stations and drip legs.

2: Chilled Water Specialties

- 3.J.2.a. Refer to Details CHW-2 and 3 for manual and automatic air vents and drains in chilled water systems.

K: PIPING INSULATION

- 1: Piping insulation and jacketing shall be per the Piping Insulation Thickness Chart including required minimum thicknesses. Individual products are specified below.
- 2: Piping Insulation Specifications
- 3: Calcium Silicate Insulation: Insulation shall be molded sections of inorganic silicate (calcium or sodium) or expanded perlite. The insulation shall conform to ASTM C533 - Type 1, ASTM C795, and ASTM E84 (0 Flame, 0 Smoke). The calcium silicate shall have a maximum service temperature of 1200 deg. F, a density of 14 LB per cubic foot, and a thermal conductivity of 0.65 BTU-in/hr-sq. ft. deg F. at a mean temperature of 700 degrees F per ASTM C335. Compressive strength shall be 100 psi to produce 5% compression per ASTM C165. Linear shrinkage shall be less than 1%. This insulation shall be certified by the manufacturer not to accelerate stress corrosion off stainless steel pipe and shall conform to ASTM C795. Acceptable products include Thermo-12 Gold and Super Caltemp Gold.
- 4: Pyrogel XTe Insulation: Aspen Aerogels, Inc. Pyrogel Xt-E with minimum 12.5 lb/ft density with k value of 0.2 Btu-in/hr – ft² –deg F at a mean temperature of 400 deg F.
- 5: Foamglas Insulation: Insulation shall be 100 percent rigid cellular glass, totally inorganic, with no binder. Absorption of moisture shall be 0.2% or less per ASTM C240. Water-vapor permeability shall be 0 perm-in per ASTM E96. Average compressive strength shall be 90 psi ASTM C165. Average density shall be 7.5 lb per cubic foot per ASTM C303. Maximum service temperature shall be 900 degrees F. Thermal conductivity shall be no greater than 0.29 Btu-in/hr-sq. Ft. - degree F at mean temperature of 75 degrees F per ASTM C177 and C518. The insulation shall conform to ASTM E84 (5 Flame, 0 Smoke). Linear expansion shall be 3 inches per 100 linear feet at 600 degrees F. Insulation shall be fabricated in half sections wherever possible. For large diameter piping where half sections are not practical, curved side wall segments are preferred. Provide double layer system with staggered joints for all systems where pipe temperature is listed as 400 degrees F or greater. Acceptable manufacturer is Foamglas by Pittsburgh Corning.
- 6: Flexible Unicellular: Pipe insulation shall be flexible unicellular sheet insulation ASTM C 534, Type II Sheet Flexible foam elastomeric thermal insulation of expanded closed cell structure, for maximum continuous temperature of minus -68 degrees F to 217 degrees F. Thermal conductivity shall be 157 BTU/HR FT degrees F at 75 degrees F. Insulation shall have a flame spread rating of 25 or less and a smoke developed rating of 100 or less when tested by ASTM E84. All fittings shall be insulated with the same insulation thickness as the adjacent piping. All seams and mitered joints shall be adhered with adhesive. Acceptable manufacturers include Aerocel, Armacell (Armaflex) and K-Flex.
- 7: Insulation of Valves: For valves 2" NPS and smaller, insulation with the insulation material specified for that service. For valves over 2" NPS, provide insulation blankets.

- 3.K.7.a. Insulation Blankets for Valves and Expansion Joints: Shall be tailor-made removable-reusable blankets for each individual valve and expansion joint. To accommodate leaks and detect their origins, blanket pieces shall have either a low point drain grommet or a mating seam at the low point which will allow water to seep through.
- 8: Provide non-porous inner and outer jackets rated for flooding conditions, constructed of minimum 13.5 ounce per square yard PTFE laminate or 32 ounce silicone glass cloth. Blanket construction shall be a double woven stitch with a minimum of 7 stitches per inch. No raw cut jacket edges shall be exposed. All blankets shall be quilted at frequent intervals with quilting fasteners or approved equal. Each blanket shall be held together with 16 gauge stainless steel wire draw strings that pass through hog rings and are spaced 3/4 inch apart. All mating edges of adjacent blankets shall be fitted with blanket hooks, spaced approximately 6 inches on centers or as required to provide securement for the stainless steel tie wire that are used to lace adjacent blankets together. Or, the blanket fasteners shall be 1-1/2 inch polypropylene side release buckles with PTFE laminate straps. Velcro is not acceptable.
- 9: For Valves: The blanket shall cover the body and the bonnet, but leave the gland follower (flange) and bolts exposed so the stem packing can be replaced without removing the blanket. The blankets shall be made and designed to fit tightly around the outside diameters of the flanges and valves, leaving no gaps when laced.
- 10: For Expansion Joints: Provide nameplate on expansion joint blanket that indicates the following information copied from the expansion joint nameplate: expansion joint number as identified in the Expansion Joint Schedule, manufacturer, model number, serial number, year fabricated, maximum pressure and temperature rating, and angular flex or rated compression and expansion and rated full pressure/temperature cycles. Locate tags in an accessible location from inside of the tunnel or manhole.
- 11: Provide different blanket style to accommodate features of each joint:
- 3.K.11.a. Bellows Style: Blanket design shall encase the unit to be insulated and provide a minimum 4 inch overlap extension over insulation of adjacent piping at cold conditions.
- 3.K.11.b. Ball Style: Expansion joint shall allow angular flexibility of joint.
- 3.K.11.c. Service: Steam and Condensate Systems: Shall be rated for the design temperature.
- 12: Acceptable products include S.L.I.M. Manhole and Tunnel Covers by Advanced Thermal Corp, Thermaxx Jackets, and Insultech Thermal Blankets by Shannon Enterprises.
- 13: Insulation inside the blankets shall be Aspen Aerogels, Inc. Pyrogel XtE. The blanket insulation thicknesses shall match the thicknesses as specified for the pipe system. The joints for multiple insulation layers shall be offset from one another.

L: PIPING SUPPORTS

- 1: The Engineer shall specify supports per ASME B31.1 in locations per the thermal stress

analysis. Provide details for all supports. Supporting from manhole top is limited to loads of 100 LBs or less. All other loads shall be supported from the floor or sides of the manhole. All support materials shall be hot dipped galvanized. Provide galvanized nuts, bolts, and washers. Refer to Details MH-3, 4, and 5.

M: PIPING INSTALLATION

- 1: All welding shall be in compliance with ASME B31.1. The Contractor shall submit Welder Procedure Specifications (WPS) for each weld type and Procedure Qualifications (PQR) for each WPS. The Contractor shall submit a Welder Qualification Test (WPQ) for each welder for each WPS. If the WPQ is more than 6 months old from the date of submittal, the Contractor shall submit evidence of continuity showing no more than a 6 month gap for each WPS submitted or else the welder must be re-qualified. In lieu of providing WPQs and evidence of continuity, the Contractor may elect to have all welders qualified on-site by an Independent Testing Agency prior to beginning work. This may be required by FS-UES under certain instances, such as critical outage work or larger projects. Each welder that is approved shall be designated a number by the Contractor – all that welder's welds shall be marked next to the weld with ink that will not burn off and located on a weld map that shall be submitted to the Owner at the end of the project.
- 2: All butt welds on steam and condensate piping systems shall have a GTAW root pass, including direct buried systems. Backing rings shall not be used.

N: PIPE TESTING

- 1: Hydrostatic Testing: Hydrostatic testing is required for all piping systems per ASME B31.1. Do not insulate any welds prior to the test. Hold pressure for 10 minutes at 1.5 the design pressure (hydrostatic test pressure stated in the Piping Index) and then reduce to operating pressure until all joints are visually inspected by FS and/or the Engineer. Where expansion joints are located in a piping system to be hydrostatically tested, all anchor construction must be completed, concrete cured, and inspections by FS and the Engineer completed before testing can begin. All tests shall be witness by FS who shall sign the Contractor's record of the test which shall include the limits of the test, date, duration, pressure, and results. The Contractor shall provide all high vents and low point drains in the piping systems no matter whether shown on the drawings. Temporary plugs may be required to test piping sections before connecting to energized piping that cannot be shutdown. An in-service test is only allowed at the discretion of FS. Use test plugs to test sections of pipe before connecting to live pipe that cannot be shut down. Pneumatic testing is not allowed.
- 2: Refer to the Piping Index for where non-destructive evaluation (NDE) of welds is required. The Engineer or FS picks the welds to be tested. The Contractor shall pay for all NDE. Per ASME B31.1, 100% of the welds shall be visually inspected (VT). It is not required that the VT be inspected by a 3rd party.
- 3: Where specified, magnetic particle testing (MT) shall be performed. This is typically on socket welded systems 2" NPS and under. All persons performing and evaluating magnetic particle examinations shall be certified for NDT Level II MT as recognized by the ANST. A Nationally Certified Level III MT technician per ASNT shall be on staff at the testing laboratory. A Corporate Level III MT without National Certification is not

acceptable.

- 4: Where specified, ultrasonic testing (UT) by phased array only shall be performed. This is typically on butt welded systems above 2" NPS. All persons performing and evaluating ultrasonic examinations will be certified for NDT Level II as recognized by the American Society for Nondestructive Testing (ANST). In lieu of UT, radiography testing can be performed, but this requires all persons within a 25 to 50 feet radius to be cleared out during the film exposure.
- 5: All test results shall be immediately sent to FS and the Engineer. Do not begin to repair a failed weld until the report has been issued and FS and the Engineer have discussed and approved the proposed weld repair procedure. If there is a failed weld, two more welds in addition to the repair shall be performed. If there are more than 2 failed welds by one welder, that welder shall be removed from the project.

O: PIPE CLEANING

- 1: Refer to the Piping Index for pipe cleaning requirements.
- 2: For steam systems, FS-UES will valve in new steam to the new piping and let the condensate drain for 4 hours or longer until needed to clear condensate to below 30 micromhos conductivity. Blow down the drip legs. Condensate will also be drained until conductivity is 50 micromhos or less.
- 3: Chilled water piping shall be flushed. The Engineer shall call out full size pipe from supply to return at the terminal points for flushing. Coordinate through FS with their chemical supplier for additional requirements of introducing and maintaining cleaning chemical through the flush process. A temporary pump may be required to maintain a minimum velocity of 2.5 ft/sec or as further clarified by the University's chemical supplier. The Contractor shall get a quote for chemicals from University's chemical supplier. Review these details for each project with FS prior to design completion. The hydrostatic test shall be completed prior to the flush.

P: VALVE TAGS AND IDENTIFICATION

- 1: Pipe markers shall indicate line contents and direction of flow. Pipe markers shall be fade-resistant, vinyl material. Snap-on or strap-on type. All markers shall have a service temperature of -40 to 175 degrees F and be rated for outdoor service. For steam, condensate, chilled water, and other related systems, marker shall be yellow with black letters and arrows. Contents markers shall have minimum 1-1/2" high letters.
- 2: Brass Tags: Provide a brass identification tag on all manual valves, steam traps, and expansion joints including those provided with a packaged piece of equipment. The identification number or designation will be provided by FS. The Engineer shall show the ID number on the schematics:
- 3: Manual valves in all piping systems shall be tagged "V-XX", where "XX" is a number designated by FS. Manual valves include gate, globe, ball, butterfly and plug style, but do not include strainers or check valves. The blowdown valves on strainers shall be tagged.

- 4: Steam traps shall be tagged "STP-XX", where "XX" is a number designated by FS.
- 5: Expansion joints shall be tagged "XJ-XX", where "XX" is a number designated by FS.
- 6: Direct buried chilled water valves shall have a brass tag with a metal embed placed in the concrete collars surrounding the valve box.
- 7: Identification of underground utilities and piping
 - 3.P.7.a. WARNING TAPE: All underground piping and utilities shall have non-detectable warning tape that conforms to the following requirements to identify the specific system buried below. Warning tape shall meet OSHA regulation 1926-956 (C) (I). Tape shall be 6" wide with black lettering imprinted on a color coded background that conforms to APWA color code specifications. Tape shall be installed between 18" to 30" above the top of the pipe and a minimum of 6" below grade.
 - 3.P.7.a.i: Any disturbance of this tape requires replacement after work is completed..
 - 3.P.7.b. TRACER WIRE: All non- metallic pipes installed underground (except pipe containing electric wires and traceable communication lines) and all piping installed 6 feet or more below grade shall have a tracer wire installed along the length of the pipe. The tracer wire shall be taped to the pipe and not allowed to "float freely" within the backfill. The tracer wire shall be continuous without splicing from access point to access point along the length of the pipe. The tracer wire shall be accessible at all structures (valve boxes, meter pits, manholes, pull boxes, lift stations) along the length of the pipe. The tracer wire shall have an access point at the beginning and ending points of the pipe run with no distance between access points to exceed 400 feet within the pipe run.
 - 3.P.7.b.i: Tracer wire shall be Copperhead™ HS-CCS with RoHS compliant HDPE 30 mil insulation that utilizes virgin grade materials, rated for direct burial use at 30 volts, with conductor rated for 21% conductivity for locating purposes with a break load of 380# minimum and made in the USA or pre-approved equal.
 - 3.P.7.b.ii: Tracer wire for piping less than 12" diameter shall be a #12 AWG and for piping greater than 12" diameter or 6 feet or more below grade shall be a #10 AWG
 - 3.P.7.b.iii: Insulation color
 - 1) For Chilled water shall be brown for supply pipes and white for return pipes.
 - 2) All others shall meet the APWA color code standard for identification of buried utilities.

Q: MANHOLES

- 1: Waterproofing

- 3.Q.1.a. All Steam and Chilled water manholes shall be waterproofed.
- 3.Q.1.b. Follow Standard 070000, 1.2 Below grade waterproofing for Steam or Chilled water manholes
- 3.Q.1.c. All seams (joints) shall have a waterstop system designed into them and a minimum 8" wide liquid membrane applied over them. This applies for precast or cast in place manholes.
 - 3.Q.1.c.i: The waterstop system is allowed to be bentonite. No other part of the waterproofing system is allowed to be bentonite.
- 3.Q.1.d. Waterproofing shall extend over all concrete surfaces, to just below the metal vault cover.

2: Forbidden Utilities

- 3.Q.2.a. Utilities that are not allowed in manholes under any circumstance include: natural gas, electric greater than 480VAC, telecom, domestic water, and storm sewer.

3: Minimum Size

- 3.Q.3.a. There are no minimum required length by width dimensions for new manholes, but they must provide adequate space for maintenance accessing piping system, including expansion joints, traps, valves, etc. The manhole minimum inside height shall be 8' so that anybody can stand in the manhole with a hardhat on. FS shall approve all manhole sizes during design after all piping is laid out and the ladder locations are shown.

4: Natural Ventilation

- 3.Q.4.a. Each manhole shall be designed with a High vent and Low vent. The High vent shall be positioned at the furthest possible location from the Low vent across the manhole and one foot from the ceiling of the manhole. The Low vent shall be positioned one foot from the bottom of the manhole.
 - 3.Q.4.a.i: The High and Low vent pipes shall be routed to a common point. The maximum length of either vent pipe shall be 30 feet. The common point shall be positioned to be out of traffic (pedestrian and vehicular) travel ways and in the most conspicuous area located near the manhole.
 - 3.Q.4.a.ii: The vent pipes shall be terminated below grade, within a vent coffer, similar to Detail STM-21.

SPECIFICATION SECTION 33 60 00
PIPING INDEX

SYSTEM	SERVICE GROUP	DESCRIPTION	CONDITIONS		PIPE SIZE (NPS)	MATERIAL	JOINTS	FLANGES (1), (2)	FITTINGS (1)	UNIONS	BOLTING MATERIALS (1)	VALVES			GASKET	INSULATION (NOTE 1)		PRESSURE TESTING	INTERNAL CLEANING	NDE (NOTE 4)						
			OPERATING	DESIGN								SHUT-OFF	THROTTLING	CHECK		GROUP	FINISH			VISUAL	MT	UT - PHASED ARRAY				
CONDENSATE, MEDIUM PRESSURE	70C	TRAP CONDENSATE FROM 70S TRAPS TO CONDENSATE RECEIVER	70 PSIG AT 335 DEG F	90 PSIG AT 474 DEG F	2 INCH AND SMALLER	SCH 80, SEAMLESS, ASTM A106 GR B	SOCKET WELD EXCEPT AT STEAM TRAPS (SEE NOTE 6)	USE UNIONS	ANSI CLASS 300 FORGED STEEL THREADED IN ACCORDANCE WITH ASME B16.11. MATERIAL PER ASTM A105	ANSI CL 300 THREADED, STEEL SEATS, PER ASTM A105	STUD - ASTM A193, GR B7 NUT - ASTM A194, GR 2H	300GATE_S_1	300GLOBE_S_1	300CHECK_S_1	FLEXITALLIC	MHs & TUNNELS: PYROGEL BLDGS: CAL SIL DIRECT BURIED: PYROGEL	MHs & TUNNELS: NO JACKET BLDGS: ALL SERVICE JACKET DIRECT BURIED FIELD FAB SYSTEM: PITTWRAP	HYDROSTATIC TO 135 PSIG	DRAIN DURING START-UP	100%	AGRND=NONE DB=100%	NONE				
CONDENSATE, HIGH PRESSURE	250C	TRAP CONDENSATE FROM 250S TRAPS TO CONDENSATE RECEIVER	210 PSIG AT 450 DEG F	270 PSIG AT 510 DEG F	2 INCH AND SMALLER	SCH 80, SEAMLESS, ASTM A106 GR B	SOCKET WELD EXCEPT AT STEAM TRAPS (SEE NOTE 6)	USE UNIONS	ANSI CLASS 3000 FORGED STEEL SOCKET WELD IN ACCORDANCE WITH ASME B16.11. MATERIAL PER ASTM A105	ANSI CL 3000, ASME B16.11, SOCKET WELD, STEEL SEATS, PER ASTM A105	STUD - ASTM A193, GR B7 NUT - ASTM A194, GR 2H	800GATE_S_1	800GLOBE_S_1	800CHECK_S_1	FLEXITALLIC	MHs & TUNNELS: PYROGEL BLDGS: CAL SIL DIRECT BURIED: PYROGEL	MHs & TUNNELS: NO JACKET BLDGS: ALL SERVICE JACKET DIRECT BURIED FIELD FAB SYSTEM: PITT WRAP	HYDROSTATIC TO 405 PSIG	DRAIN DURING START-UP	100%	AGRND=NONE DB=100%	NONE				
CONDENSATE, PUMPED	PC	CAMPUS CONDENSATE, RETURNED FROM CAMPUS TO RABON OR OTHER COND RECEIVER	30 PSIG AT 160 DEG F	75 PSIG AT 250 DEG F	2 INCH AND SMALLER	SCH 80, SEAMLESS, ASTM A106 GR B	SOCKET WELD EXCEPT AT STEAM TRAPS (SEE NOTE 6)	USE UNIONS	ANSI CLASS 300 FORGED STEEL THREADED IN ACCORDANCE WITH ASME B16.11. MATERIAL PER ASTM A105	ANSI CL 300 THREADED, STEEL SEATS, PER ASTM A105	STUD - ASTM A193, GR B7 NUT - ASTM A194, GR 2H	250BALL_S_1	NONE	150CHECK_S_1	FLEXITALLIC	MHs & TUNNELS: PYROGEL BLDGS: CAL SIL DIRECT BURIED: PYROGEL	MHs & TUNNELS: NO JACKET BLDGS: ALL SERVICE JACKET DIRECT BURIED FIELD FAB SYSTEM: PITT WRAP	HYDROSTATIC TO 112.5 PSIG	DRAIN DURING START-UP	100%	AGRND=NONE DB=100%	NONE				
					2-1/2 INCH THRU 16 INCH	SCH STD, SEAMLESS, ASTM A106 GR B	BUTT WELD	ANSI CL 150 WELD NECK, R.F. PER ASME B16.5. MATERIAL SHALL BE ASTM A105	SAME THICKNESS AS PIPE, BUTT WELD PER ASME B16.9, MATERIAL PER ASTM A 234, GR WPB	UNIONS SHALL BE MADE WITH FLANGES	STUD - ASTM A193, GR B7 NUT - ASTM A194, GR 2H	150BUTTER_F_1, 150GATE_F_1 (NOTE V2)	NONE	150CHECK_F_1	100%	NONE	AGRND=NONE DB=100%									
DRAINS, EQUIPMENT	ED	DRAINS FROM ALL SERVICES	ATMOSPHERIC	N/A	PIPING MATERIALS SHALL MATCH SYSTEM BEING DRAINED											NO VALVES IN THIS SYSTEM			COMPRESSED SHEET, NITRILE BINDER	NONE	NONE	6.5 PSIG OR 15 FT WATER COLUMN OR INITIAL SERVICE LEAK TEST	NONE	NONE	NONE	NONE
STEAM, MEDIUM PRESSURE	70S	MEDIUM PRESSURE STEAM	70 PSIG AT 335 DEG F	90 PSIG AT 474 DEG F	2 INCH AND SMALLER	SCH 80, SEAMLESS, ASTM A106 GR B	SOCKET WELD EXCEPT AT STEAM TRAPS (SEE NOTE 6)	USE UNIONS	ANSI CLASS 300 FORGED STEEL THREADED IN ACCORDANCE WITH ASME B16.11. MATERIAL PER ASTM A105	ANSI CL 300 THREADED, STEEL SEATS, PER ASTM A105	STUD - ASTM A193, GR B7 NUT - ASTM A194, GR 2H	300GATE_S_1	300GLOBE_S_1, 800GLOBE_S_1 (NOTE V1)	300CHECK_S_1	FLEXITALLIC	MHs & TUNNELS: PYROGEL BLDGS: CAL SIL DIRECT BURIED: PYROGEL	MHs & TUNNELS: NO JACKET BLDGS: ALL SERVICE JACKET DIRECT BURIED FIELD FAB SYSTEM: PITT WRAP	HYDROSTATIC TO 135 PSIG	EXTENDED DRAINING DURING START-UP	100%	AGRND=NONE DB=100%	NONE				
					2-1/2 INCH THROUGH 20 INCH	SCH STD, SEAMLESS, ASTM A106 GR B	BUTT WELD	ANSI CL 150 WELD NECK, R.F. PER ASME B16.5. MATERIAL SHALL BE ASTM A105	SAME THICKNESS AS PIPE, BUTT WELD PER ASME B16.9, MATERIAL PER ASTM A 234, GR WPB	UNIONS SHALL BE MADE WITH FLANGES	STUD - ASTM A193, GR B7 NUT - ASTM A194, GR 2H	150BUTTER_F_1, 150GATE_F_1 (NOTE V2)	150GLOBE_F_1	NONE	100%	NONE	AGRND=10% DB=100%									
STEAM, HIGH PRESSURE	250S	HIGH PRESSURE STEAM IN 250 PSIG SYSTEM FROM RABON/DUKE TO USE INCLUDING WEIL HALL	210 PSIG AT 450 DEG F	270 PSIG AT 510 DEG F	2 INCH AND SMALLER	SCH 80, SEAMLESS, ASTM A106 GR B	SOCKET WELD EXCEPT AT STEAM TRAPS (SEE NOTE 6)	USE UNIONS	ANSI CLASS 3000 FORGED STEEL SOCKET WELD IN ACCORDANCE WITH ASME B16.11. MATERIAL PER ASTM A105	ANSI CL 3000, ASME B16.11, SOCKET WELD, STEEL SEATS, PER ASTM A105	STUD - ASTM A193, GR B7 NUT - ASTM A194, GR 2H	800GATE_S_1	800GLOBE_S_1	800CHECK_S_1	FLEXITALLIC	MHs & TUNNELS: PYROGEL BLDGS: CAL SIL DIRECT BURIED: PYROGEL	MHs & TUNNELS: NO JACKET BLDGS: ALL SERVICE JACKET DIRECT BURIED FIELD FAB SYSTEM: PITT WRAP	HYDROSTATIC TO 405 PSIG	EXTENDED DRAINING DURING START-UP	100%	AGRND=10% DB=100%	NONE				
					2-1/2 INCH THROUGH 12 INCH	SCH STD, SEAMLESS, ASTM A106 GR B	BUTT WELD	ANSI CL 300 WELD NECK, R.F. PER ASME B16.5. MATERIAL SHALL BE ASTM A105	SAME THICKNESS AS PIPE, BUTT WELD PER ASME B16.9, MATERIAL PER ASTM A 234, GR WPB	UNIONS SHALL BE MADE WITH FLANGES	STUD - ASTM A193, GR B7 NUT - ASTM A194, GR 2H	150BUTTER_F_1, 150GATE_F_1 (NOTE V2)	NONE	NONE	100%	NONE	AGRND=10% DB=100%									
VENTS	VENT	VENTS FROM MANHOLES	ATMOSPHERIC	N/A	2-1/2 INCH THROUGH 20 INCH	SCH STD, ERW, ASTM A53 GR B	BUTT WELD	ANSI CL 150 WELD NECK, R.F. PER ASME B16.5. MATERIAL SHALL BE ASTM A105	SAME THICKNESS AS PIPE, BUTT WELD PER ASME B16.9, MATERIAL PER ASTM A 234, GR WPB	UNIONS SHALL BE MADE WITH FLANGES	STUD - ASTM A193, GR B7 NUT - ASTM A194, GR 2H	NO VALVES IN THIS SYSTEM			COMPRESSED SHEET, NITRILE BINDER	NONE	NONE	6.5 PSIG OR 15 FT WATER COLUMN OR INITIAL SERVICE LEAK TEST	NONE	NONE	NONE	NONE				
WATER, CHILLED WATER (CARBON STEEL SYSTEM)	CHWS, CHWR	CHILLED WATER SUPPLY AND RETURN FOR ALL LOCATIONS NOT DIRECT BURIED AND FOR DIRECT BURIED 12" NPS AND SMALLER	PRESSURE: ASK FS TEMP: SUPPLY 42 DEG F, OUTLET 52 DEG F	PRESSURE: ASK FS TEMP: SUPPLY 40 DEG F, RETURN 65 DEG F	2 INCH AND SMALLER	SCH 80, SEAMLESS, ASTM A53 GR B OR A106 GR B	SCREWED	USE UNIONS	CLASS 150 SCREWED BANDED MALLEABLE IRON PER ASME B16.3, MATERIAL PER ASTM A 197	CLASS 150 MALLEABLE IRON, BRASS SEAT, NUT TYPE. MATERIAL PER ASTM A 197.	STUD - ASTM A193, GR B7 NUT - ASTM A194, GR 2H	150GATE_S_1	150GLOBE_S_1	150CHECK_S_1	COMPRESSED SHEET, NITRILE BINDER	MHs & TUNNELS: FOAMGLAS BLDGS: FOAMGLAS STUB-OUTS IN MHs, TUNNELS, & BLDGS: FLEXIBLE UNICELLULAR (NOTE I2) DIRECT BURIED: POLYURETHANE FOAM DIRECT BURIED FIELD FAB SYSTEM: FOAMGLAS	MHs & TUNNELS: ALUMINUM JACKET BLDGS: ALUMINUM JACKET DIRECT BURIED FIELD FAB SYSTEM: PITT WRAP	HYDROSTATIC TO 1.5 TIMES THE DESIGN PRESSURE AS APPROVED BY FS	WATER FLUSH WITH CHEMICAL CLEANING	100%	AGRND=NONE DB=100%	NONE				
					2-1/2 INCH THROUGH 24 INCH	SCH STD, SEAMLESS, ASTM A53 GR B OR A106 GR B		BUTT WELD	ANSI CL 150 WELD NECK, R.F. PER ASME B16.5. MATERIAL SHALL BE ASTM A105	SAME THICKNESS AS PIPE, BUTT WELD PER ASME B16.9, MATERIAL PER ASTM A 234, GR WPBW	UNIONS SHALL BE MADE WITH FLANGES	STUD - ASTM A193, GR B7 NUT - ASTM A194, GR 2H	150BUTTER_F_1	150GLOBE_F_1						150CHECK_F_1	100%	NONE	AGRND=10% DB=100%			
WATER, CHILLED WATER (HDPE - HIGHER PRESSURE SYSTEM)	CHWS, CHWR	CHILLED WATER SUPPLY AND RETURN FOR ALL DIRECT BURIED LOCATIONS 14" AND HIGHER IN HIGHER PRESSURE SYSTEMS AS DIRECTED BY FS	PRESSURE: ASK FS TEMP: SUPPLY 42 DEG F, OUTLET 52 DEG F	PRESSURE: ASK FS TEMP: SUPPLY 40 DEG F, RETURN 65 DEG F	14 INCH AND LARGER	HDPE PER PE4710 PER AWWA C906 AND ASTM F714, 200 PSI (DR11), OIPS SIZING BASED ON OD ASTM D3035. RESIN PER ASTM 3350.	FUSION WELD	NOT USED. REFER TO SPEC FOR TRANSITION FITTING REQUIREMENTS TO CARBON STEEL.	SAME RATING, MATERIAL, OD, AND THICKNESS AS PIPE	NOT USED	NOT USED	NONE	NONE	NONE	NONE	POLYURETHANE	NONE	HYDROSTATIC TO 1.5 TIMES THE DESIGN PRESSURE AS APPROVED BY FS	WATER FLUSH WITH CHEMICAL CLEANING	NOTE 5	NONE	NONE				
WATER, CHILLED WATER (HDPE - LOWER PRESSURE SYSTEM)	CHWS, CHWR	CHILLED WATER SUPPLY AND RETURN FOR ALL DIRECT BURIED LOCATIONS 14" AND HIGHER IN LOWER PRESSURE SYSTEMS AS DIRECTED BY FS	PRESSURE: ASK FS TEMP: SUPPLY 42 DEG F, OUTLET 52 DEG F	PRESSURE: ASK FS TEMP: SUPPLY 40 DEG F, RETURN 65 DEG F	14 INCH AND LARGER	HDPE PER PE4710 PER AWWA C906 AND ASTM F714, 125 PSI (DR11), OIPS SIZING BASED ON OD ASTM D3035. RESIN PER ASTM 3350.	FUSION WELD	NOT USED. REFER TO SPEC FOR TRANSITION FITTING REQUIREMENTS TO CARBON STEEL.	SAME RATING, MATERIAL, OD, AND THICKNESS AS PIPE	NOT USED	NOT USED	NONE	NONE	NONE	NONE	POLYURETHANE	NONE	HYDROSTATIC TO 1.5 TIMES THE DESIGN PRESSURE AS APPROVED BY FS	WATER FLUSH WITH CHEMICAL CLEANING	NOTE 5	NONE	NONE				

IDENTIFIED NOTES:

- INSIDE DIAMETER OF FLANGE/FITTING SHALL MATCH MATING PIPE INSIDE DIAMETER. THICKNESS SHALL MATCH SPECIFIED PIPE THICKNESS.
- MACHINE TO FLAT FACE IF MATING FLANGE IS FLAT FACE.
- BOLTING SHALL CONSIST OF A BOLT HEAD WHICH REQUIRES ONE NUT ON THE OPPOSITE SIDE OF THE THREADED END IN ACCORDANCE WITH ANSI B1.1, CLASS 2A.
- "AGRND" = NOT DIRECT BURIED (I.E. IN MANHOLE, TUNNEL, OR BLDG), "DB" = DIRECT BURIED.
- REFER TO SPEC FOR FUSION WELDING LOG REQUIREMENTS. REQUIRED FOR EVERY FUSION WELD.
- STEAM TRAPS AND CONNECTED UNIONS SHALL BE THREADED.

VALVE NOTES:

- USE THIS SELECTION FOR STEAM BY-PASS VALVES FOR WARM-UP SERVICE.
- PROVIDE GATE VALVES ONLY WHERE DIRECTED BY FACILITIES SERVICES.

INSULATION NOTES:

- REFER TO SEPARATE PIPING INSULATION THICKNESS CHART.
- PROVIDE FLEXIBLE UNICELLULAR INSULATION FOR ALL AIR VENTS, PRESSURE GAUGES, AND DRAIN STUB-OUTS FROM MAINS IN MANHOLES, TUNNELS, AND BUILDINGS.

PIPING INSULATION THICKNESS CHART
UNIVERSITY OF FLORIDA

INSULATION TYPE	CAL SIL INSULATION		PYROGEL XTE				FOAMGLAS			POLYURETHANE	FLEXIBLE UNICELLULAR				
PIPE SIZE (NPS)	MINIMUM INSULATION THICKNESS (INCHES)														
1/2"	2	3	0.8	1.6	NOTE 3	NOTE 3	1.5	1.5	2	2.5	1				
3/4"				1.8							1.5	1.5	2	2.5	1.5
1"															2
1-1/4"				1							2	2	2	2	
1-1/2"			1.2				2.2	2	2	2					
2"				1.4							2.2	2	2	2	
2-1/2"			N/A				N/A	N/A	N/A	N/A					N/A
3"				N/A							N/A	N/A	N/A	N/A	
4"			N/A				N/A	N/A	N/A	N/A					N/A
6"				N/A							N/A	N/A	N/A	N/A	
8"			N/A				N/A	N/A	N/A	N/A					N/A
10"				N/A							N/A	N/A	N/A	N/A	
12"			N/A				N/A	N/A	N/A	N/A					N/A
14"				N/A							N/A	N/A	N/A	N/A	
16"	N/A	N/A	N/A		N/A	N/A	N/A								
20"				N/A				N/A	N/A	N/A	N/A	N/A			
24" AND LARGER	N/A	N/A	N/A		N/A	N/A	N/A								

- NOTES: 1. REFER TO PIPE INDEX FOR PIPE SPECIFICATION AND INSULATION FINISH.
 2. PROVIDE FLEXIBLE UNICELLULAR INSULATION FOR ALL AIR VENTS, PRESSURE GAUGES, AND DRAIN STUB-OUTS FROM MAINS IN MANHOLES, TUNNELS, AND BUILDINGS FOR CHILLED WATER SERVICES.
 3. INSULATION THICKNESS SHALL BE SIZED BY DIRECT BURIED MANUFACTURER TO KEEP OUTER JACKET TEMPERATURE TO 100 DEG F OR LOWER CONSIDERING 30 mm MINIMUM AEROGEL INSULATION ON PIPE, 1" AIR GAP, AND 1" MINIMUM POLYURETHANE OUTER CONDUIT INSULATION. MANUFACTURER MUST SUBMIT CALCULATION FOR SURFACE TEMPERATURE CONSIDERING OPERATING TEMPERATURE OF PIPING INDEX.

VALVE CHART UNIVERSITY OF FLORIDA			
VALVE STYLE	VALVE SYMBOL	VALVE SIZE (NPS)	VALVE SPECIFICATION
GATE	150GATE_S_1	2 Inches and Smaller	Class 150 gate valve, screwed ends, cast bronze body and bonnet, bronze stem, union bonnet, solid disc gate, inside screw, rising stem; disc and renewable seat ring of 13 percent chromium stainless steel, body and bonnet material to conform to ASTM B 61 or B 62. The valve shall conform to MSS SP-80, Class 150-B62, Type 2. Manufacturer shall be Apollo, Nibco, Powell, or Stockham.
	300GATE_S_1	2 Inches and Smaller	Class 300 gate valve, screwed ends, cast bronze body and bonnet, bronze stem, union bonnet, solid disc gate, inside screw, rising stem; disc and renewable seat ring of 13 percent chromium stainless steel, body and bonnet material to conform to ASTM B 61 or B 62. The valve shall conform to MSS SP-80, Class 300-B62, Type 2. Manufacturer shall be Apollo, Nibco, Powell, or Stockham.
	800GATE_S_1	2 Inches and Smaller	Class 600 or 800 gate valve, forged or cast carbon steel body and bonnet, screwed ends; 13 percent chromium stainless steel seat rings, disc and stem; bolted or union bonnet, solid wedge disc, renewable or integral stellite or cobalt based alloy hard faced seat rings, outside screw and yoke, rising stem, body and bonnet materials to conform to ASTM A 105 or A 216, Grade WCB. Working pressure and temperature ratings shall comply with ANSI B16.34 (Standard Class). Manufacturer shall be Bonney Forge, Powell, Sharpe, Velan, or Vogt.
	150GATE_F_1	2-1/2 Inches and Larger	Class 150 steel gate valve, flanged ends, bolted flanged bonnet, outside screw and yoke, rising stem, flexible or solid wedge disc, renewable seat rings and disc. Materials shall be: Body and bonnet, ASTM A 216, Grade WCB or A105; stem, 13 percent chromium stainless steel; disc face and seat rings 13 percent chromium stainless steel or a combination of 13 percent chromium stainless steel and nickel-copper, stellite or a combination of stellite and 13 percent chromium stainless steel as recommended by its manufacturer for steam service. Face to face dimension shall conform to ANSI B16.10. Flanges shall be faced and drilled to ANSI B16.5. Working pressure and temperature ratings shall comply with ANSI B16.34 (Standard Class). Where noted on the Contract Drawings provide an enclosed gear operator. Manufacturer shall be Crane, Nibco, Powell, Sharpe, or Velan.
	300GATE_F_1	2-1/2 Inches and Larger	Class 300 steel gate valve, flanged ends, bolted flanged bonnet, outside screw and yoke, rising stem, flexible or solid wedge disc, renewable seat rings. Materials shall be: Body and bonnet, ASTM A 216, Grade WCB or A105; stem, 13 percent chromium stainless steel; disc face and seat rings 13 percent chromium stainless steel and nickel-copper, stellite or a combination of stellite and 13 percent chromium stainless steel as recommended by its manufacturer for steam service. Face to face dimension shall conform to ANSI B16.10. Flanges shall be faced and drilled to ANSI B16.5. Working pressure and temperature ratings shall comply with ANSI B16.34 (Standard Class). Manufacturer shall be Crane, Nibco, Powell, Sharpe, or Velan.
GLOBE	150GLOBE_S_1	2 Inches and Smaller	Class 150 globe valve, screwed ends, cast bronze body and bonnet, bronze stem, union bonnet, plug or semi-plug type disc, inside screw, rising stem; disc and renewable seat ring of 13 percent chromium stainless steel, body and bonnet material to conform to ASTM B 61 or B 62. The valve shall conform to MSS SP-80, Class 150-B62, Type 2. Manufacturer shall be Apollo, Nibco, Powell, or Stockham.
	300GLOBE_S_1	2 Inches and Smaller	Class 300 globe valve, screwed ends, cast bronze body and bonnet, bronze stem, union bonnet, plug or semi-plug type disc, inside screw, rising stem; disc and renewable seat ring of 13 percent chromium stainless steel, body and bonnet material to conform to ASTM B 61 or B 62. The valve shall conform to MSS SP-80, Class 300-B62, Type 2. Manufacturer shall be Apollo, Nibco, Powell, or Stockham.
	800GLOBE_S_1	2 Inches and Smaller	Class 600 or 800 globe valve, forged or cast carbon steel body and bonnet, screwed ends, 13 percent chromium stainless steel disc and stem; stellite seat ring; bolted bonnet, plug or semi-plug type disc, renewable or integral hard faced seat ring, outside screw and yoke, rising stem, body and bonnet material to conform to A 105 or A 216, Grade WCB. Working pressure and temperature ratings shall comply with ANSI B16.34 (Standard Class). Manufacturer shall be Bonney Forge, Powell, Sharpe, Velan, or Vogt.
	150GLOBE_F_1	2-1/2 Inches and Larger	Class 150 steel globe valve, flanged ends, bolted flanged bonnet, outside screw and yoke, rising stem, plug or semi-plug type disc, renewable seat rings and disc. Materials shall be: Body and bonnet, ASTM A 216, Grade WCB or A105; stem, 13 percent chromium stainless steel; seat ring, 13 percent chromium stainless steel; disc, 13 percent chromium stainless steel or 13 percent chromium stainless steel faced. Face to face dimension shall conform to ANSI B16.10. Flanges shall be faced and drilled to ANSI B16.5. Working pressure and temperature ratings shall comply with ANSI B16.34 (Standard Class). Manufacturer shall be Crane, Nibco, Powell, Sharpe, or Velan.
CHECK	150CHECK_S_1	2 Inches and Smaller	Class 150 horizontal swing check valve, cast bronze body and cover, screwed ends, bronze disc, screwed cover, integral seat, body and cover material to conform to ASTM B 61 or B 62. The valve shall conform to MSS SP-80, Class 150-B62, Type 3. Manufacturer shall be Apollo, Nibco, Powell, or Stockham.
	300CHECK_S_1	2 Inches and Smaller	Class 300 horizontal swing check valve, cast bronze body and cover, screwed ends, bronze disc, screwed cover, integral seat, body and cover material to conform to ASTM B 61 or B 62. The valve shall conform to MSS SP-80, Class 300-B62, Type 3. Manufacturer shall be Apollo, Nibco, Powell, or Stockham.
	800CHECK_S_1	2 Inches and Smaller	Class 600 or 800 horizontal or vertical swing check valve; forged carbon steel body; screwed ends; 13 percent chromium stainless steel disc; renewable or integral stellite seat ring; body material to conform to ASTM A 105. Working pressure and temperature ratings shall comply with ANSI B16.34 (Standard Class). Manufacturer shall be Bonney Forge, Powell, Sharpe, Velan, or Vogt.
	150CHECK_F_1	2-1/2 Inches and Larger	Class 150 steel horizontal swing check valve, flanged ends, bolted flanged cover and renewable seat ring. Body material shall conform to ASTM A 216, Grade WCB or A 105. Disc or disc seating face and the seat ring shall be 13 percent chromium stainless steel. Face to face dimension shall conform to ANSI B16.10. Flange shall be faced and drilled to ANSI B16.5. Working pressure and temperature ratings shall comply with ANSI B16.34 (Standard Class). Manufacturer shall be Crane, Nibco, Powell, Sharpe, or Velan.
BALL	250BALL_S_1	2-1/2 Inches and Smaller	Rated for 250 pound saturated steam service, carbon steel body with 316 stainless steel ball and stem, reinforced teflon seats and seals which are rated for 250 pound saturated steam service with flashing service. Valve shall have threaded ends. Valve shall have standard bore size. Valve shall have one piece body. Valve shall have blow-out proof stem design and shall have zinc plated carbon steel lever with vinyl grip. Valve lever shall have design so that lock-out can easily occur. Manufacturer shall be Apollo, McCanna, or Sharpe.
BUTTERFLY	150BUTTER_F_1	3 Inches and Larger	Triple or quadruple offset butterfly style, rotary valve, Class 150, carbon steel body conforming to ASTM A216, Type WCB. For applications where an existing valve is not being replaced in kind, provide a lug body style. For applications where an existing valve is being replaced in kind and the work must be done quickly to avoid a prolonged outage, provide a long pattern double flanged body valve with the laying length face-to-face in conformance with ANSI B16.10. Consult with FS for each application. The disk movement relative to the shaft rotation shall be double offset design. Shaft shall be blow-out proof, 17-4 PH stainless, and single piece construction. Seats shall be replaceable and bolted to the valve body. Seats shall be stellite or similar hard surfaced metal. Seats shall be resilient, non-flexing laminate metal seal composite of stainless steel and graphite retained such that centering movement is permitted. Retainer screws, disk, and plate shall be stainless steel. The hardened bearing with bearing seal shall be retained in the body. The shaft seal shall be graphite with multiple stud packing gland follower for adjustability. Valve and valve seat shall be designed and rated for water and steam service at pressure and differential pressures to Class 150 ANSI B16.34 (Standard Class) for bi-directional shut-off (zero leakage) dead-end service. Position indicator for sizes 2-1/2 through 24 inches. Provide right angle gear operator with loose steel hand wheel or chain wheel attachment for remote "tee" handle operation as shown on drawings. Valve actuator shall be provided with self-locking gears. Provide stem housing to allow for minimum of 3 inches insulation. Valve shall be designed and manufactured in accordance with API 607, Fourth Edition. The Owner stocks Bray Controls Tri Lok triple offset butterfly valves. Provide these valves. Quadax quadruple offset valves will be considered as well as Velan Torqseal triple offset valves.
	300BUTTER_F_1	3 Inches and Larger	Triple or quadruple offset butterfly style, rotary valve, Class 300, carbon steel body conforming to ASTM A216, Type WCB. For applications where an existing valve is not being replaced in kind, provide a lug body style. For applications where an existing valve is being replaced in kind and the work must be done quickly to avoid a prolonged outage, provide a long pattern double flanged body valve with the laying length face-to-face in conformance with ANSI B16.10. Consult with FS for each application. The disk movement relative to the shaft rotation shall be double offset design. Shaft shall be blow-out proof, 17-4 PH stainless, and single piece construction. Seats shall be replaceable and bolted to the valve body. Seats shall be stellite or similar hard surfaced metal. Seats shall be resilient, non-flexing laminate metal seal composite of stainless steel and graphite retained such that centering movement is permitted. Retainer screws, disk, and plate shall be stainless steel. The hardened bearing with bearing seal shall be retained in the body. The shaft seal shall be graphite with multiple stud packing gland follower for adjustability. Valve and valve seat shall be designed and rated for water and steam service at pressure and differential pressures to Class 300 ANSI B16.34 (Standard Class) for bi-directional shut-off (zero leakage) dead-end service. Position indicator for sizes 2-1/2 through 24 inches. Provide right angle gear operator with loose steel hand wheel or chain wheel attachment for remote "tee" handle operation as shown on drawings. Valve actuator shall be provided with self-locking gears. Provide stem housing to allow for minimum of 3 inches insulation. Valve shall be designed and manufactured in accordance with API 607, Fourth Edition. The Owner stocks Bray Controls Tri Lok triple offset butterfly valves. Provide these valves. Quadax quadruple offset valves will be considered as well as Velan Torqseal triple offset valves.

NOTES: 1. REFER TO THE PIPING INDEX TO DETERMINE WHICH PIPE SYSTEMS GET WHICH VALVES.

INDEX OF STANDARD DETAILS FOR STEAM AND CHILLED WATER UTILITY SYSTEMS
UNIVERSITY OF FLORIDA - FACILITIES SERVICES



DETAIL NO.	DETAIL NAME	REV# & ISSUE DATE
CHW-1	DETAIL - BUILDING CHILLED WATER REQUIREMENTS INCLUDING FLOW METERS	REV 0, 05/29/18
CHW-2	DETAIL - CHILLED WATER MANHOLE VENTING, MANWAY LOCATIONS, AND LADDER	REV 0, 05/29/18
CHW-3	DETAIL - CHILLED WATER DRAIN CONNECTION & AIR VENT	REV 0, 05/29/18
CHW-4	DETAIL - CHILLED WATER MANHOLE ISOLATION VALVES - BI-DIRECTIONAL FLOW	REV 0, 05/29/18
CHW-5	DETAIL - HDPE TO STEEL TRANSITION	REV 0, 08/21/18
CHW-6	DETAIL - SUMP PUMP - ELECTRIC POWERED	REV 0, 12/17/20
CHW-7	DETAIL - DIRECT BURIED VALVE IDENTIFIER	REV 0, 05/26/21
MH-1	DETAIL - FIBRELITE MANHOLE FRAME AND COVER	REV 0, 05/29/18
MH-2	DETAIL - MINIMUM DISTANCE TO UTILITIES	REV 0, 05/29/18
MH-3	DETAIL - PIPE GUIDE SUPPORT	REV 1, 03/29/19
MH-4	DETAIL - PIPE ROLLER SUPPORT	REV 1, 03/29/19
MH-5	DETAIL - PIPE SLIDE SUPPORT	REV 1, 03/29/19
MH-6	DETAIL - PRESSURE GAUGES	REV 1, 03/29/19
MH-7	DETAIL - VALVE INSULATION BLANKETS	REV 0, 05/29/18
MH-8	DETAIL - WALL PENETRATION	REV 0, 05/29/18
STM-1	DETAIL - BUILDING PUMPED CONDENSATE FLOW METERS	REV 1, 03/24
STM-2	DETAIL - BUILDING STEAM & CONDENSATE REQUIREMENTS	REV 2, 003/24
STM-3	DETAIL - BUILDING STEAM FLOW METERS	REV 0, 05/29/18
STM-4	DETAIL - CONNECTION OF EXISTING DIRECT BURIED PIPING TO REHAB STEAM MANHOLE	REV 0, 05/29/18
STM-5	DETAIL - CONNECTION OF NEW DIRECT BURIED PIPE TO EXISTING BEYOND MANHOLE	REV 0, 05/29/18
STM-6	DETAIL - PSAN DROP IN SANITARY MANHOLE	REV 0, 05/29/18
STM-7	DETAIL - REHAB STEAM MANHOLE	REV 1, 06/17/21
STM-8	DETAIL - SCHEDULE - EXPANSION JOINTS	REV 0, 05/29/18
STM-9	DETAIL - SCHEDULE - FLOW METERS	REV 0, 05/29/18
STM-10	DETAIL - SCHEDULE - STEAM TRAPS	REV 0, 05/29/18
STM-11	DETAIL - SCHEDULE - SUMP PUMP	REV 0, 05/29/18
STM-12	DETAIL - STEAM & CONDENSATE MANHOLE ISOLATION VALVES - ONE-DIRECTIONAL BRANCH FLOW	REV 1, 03/29/19
STM-13	DETAIL - STEAM MANHOLE VENTING, MANWAY LOCATIONS, AND LADDER	REV 2, 09/22
STM-14	DETAIL - STEAM SYSTEM WARM-UP VALVE	REV 0, 05/29/18
STM-15	DETAIL - STEAM TRAP STATION AND DRIP-LEG CONFIGURATION	REV 3, 05/24/21
STM-16	DETAIL - STEAM & CONDENSATE ANCHORS, GUIDES, & EXPANSION JOINTS	REV 1, 03/29/19
STM-17	DETAIL - STEAM & CONDENSATE DIRECT BURIED SYSTEM UTILITY TRENCH SECTION	REV 0, 05/29/18
STM-18	DETAIL - SUMP PUMP - ELECTRIC POWERED	REV 1, 09/22
STM-19	DETAIL - SUMP PUMP - STEAM POWERED	REV 2, 09/22
STM-20	DETAIL - THERMAL STRESS REQUIREMENTS	REV 0, 05/29/18
STM-21	DETAIL - VENT COFFER FOR PAVED AREAS	REV 3, 03/24
STM-22	DETAIL - VENT COFFER FOR UNPAVED AREAS	REV 0, 03/24

INSERTION ELECTROMAGNETIC
CHILLED WATER FLOW METER
RANGES TO DETERMINE
METER PIPE SIZE

CHILLED WATER FLOW RANGE (GPM)	FLOW METER SIZE (NPS INCHES)
1-200	2
4-800	4
9-1,800	6
16-3,100	8
24-4,900	10
35-7,000	12
55-11,400	16

DETAIL NOTES:

1. PROVIDE AUTOMATIC AIR VENTS AT HIGH POINTS ASSUMING ALL VALVES OPEN.

DRAWING NOTES:

- 1 PROVIDE 3/4" MANUAL VENT VALVES AT HIGH POINTS WHERE AIR CAN BE TRAPPED BY CLOSED VALVES IN THE MAIN.
- 2 PROVIDE 2" MANUAL DRAINS AT ALL LOW POINTS INCLUDING THOSE CREATED BY CLOSED VALVES IN THE MAINS.
- 3 PROVIDE REDUCERS WHEN NECESSARY TO GET FLOW METER IN RANGE PER TABLE.
- 4 IF MINIMUM STRAIGHT RUNS ARE NOT AVAILABLE, CONSULT WITH FACILITIES SERVICES FOR ALTERNATE METER SELECTION.

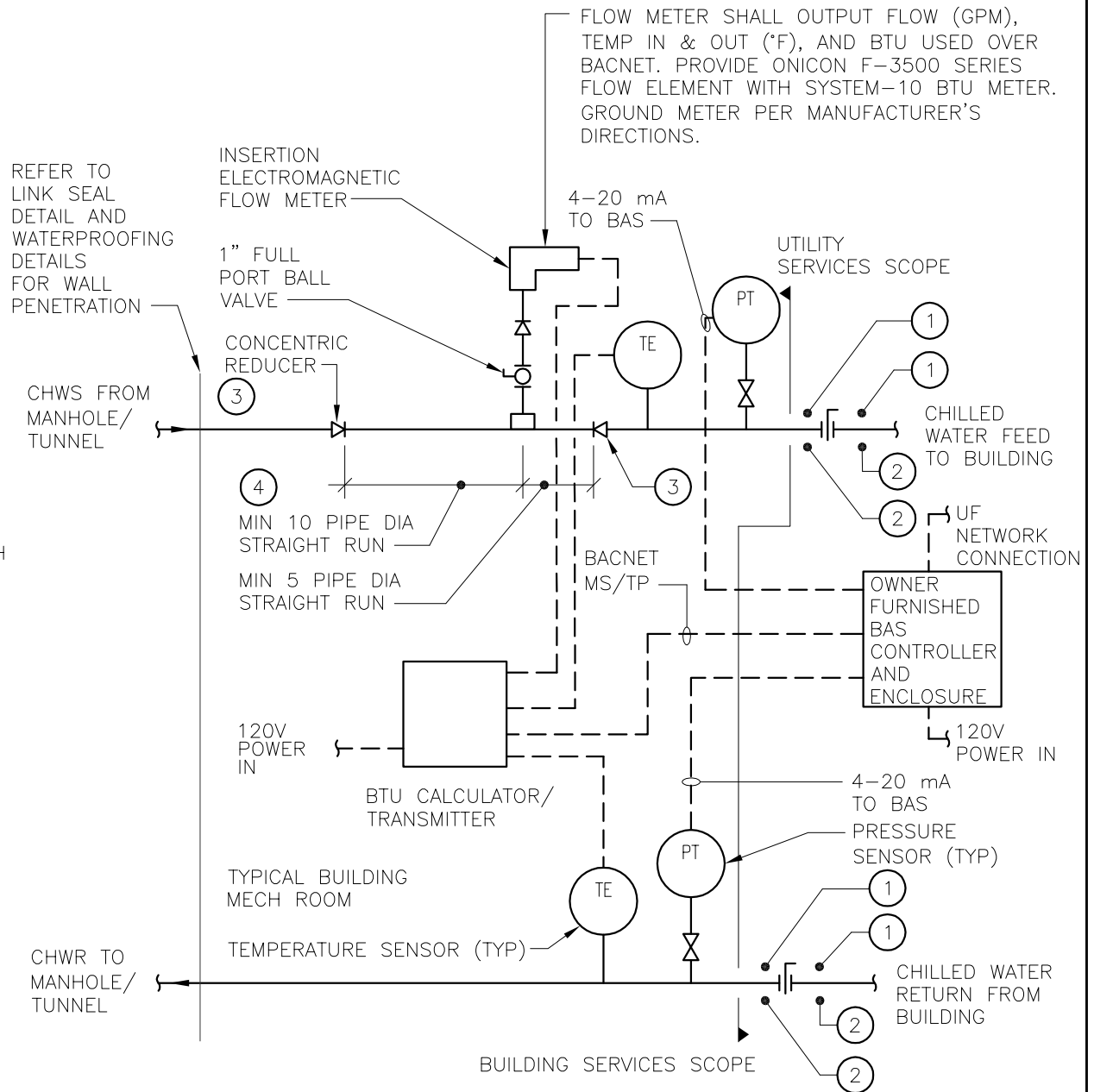

DETAIL CHW-1 - BUILDING CHILLED WATER REQUIREMENTS INCLUDING FLOW METERS

REV 0, 05/29/18



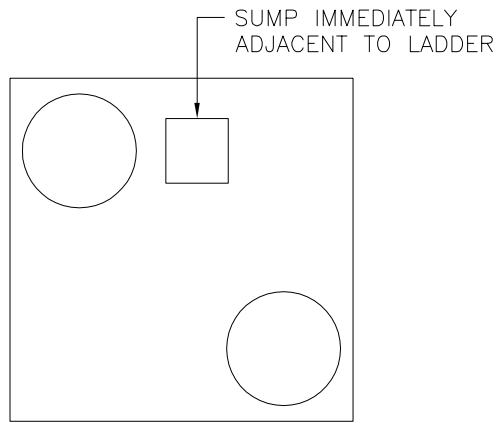

PLAN

1. LOCATE MANWAYS IN OPPOSITE CORNERS.
2. AVOID LOCATING MANWAYS IN ROADS WHERE POSSIBLE. DO NOT LOCATE UNDER PARKING SPACES.
3. DO NOT LOCATE ANY PIPING UNDER MANHOLE LIDS.

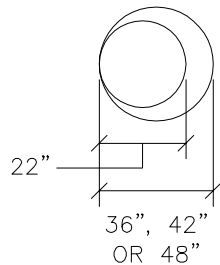

PROVIDE MANHOLE LID INSIDE MANHOLE LID FOR AT LEAST ONE OF THE TWO. OTHER MANHOLE LID SHALL BE MINIMUM 36"Ø. CONFIRM LARGER DIAMETER WITH FACILITIES SERVICES. PROVIDE LIDS THAT SHARE A COMMON TANGENT AS SHOWN (NOT LID CENTERED IN LID) SO LADDER CAN BE USED.

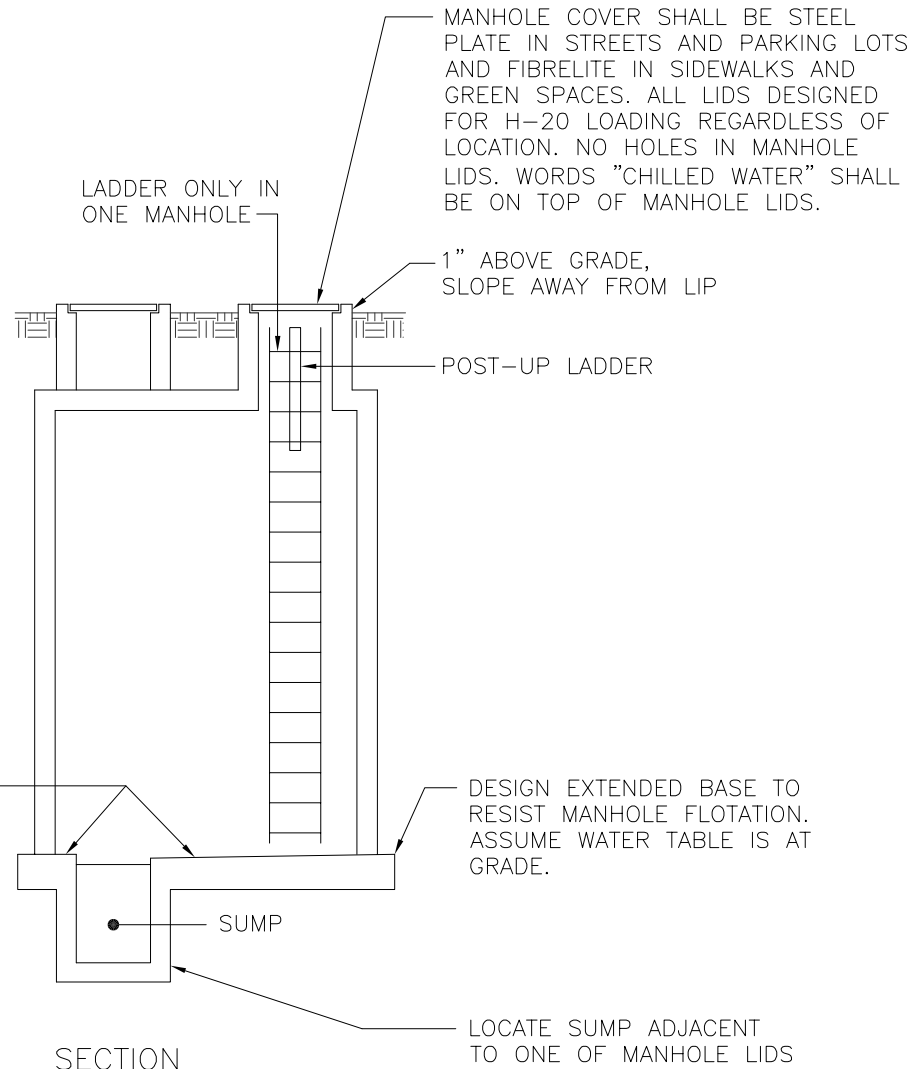

SECTION

DETAIL CHW-2 – CHILLED WATER MANHOLE VENTING, MANWAY LOCATIONS, AND LADDER

REV 0, 05/29/18

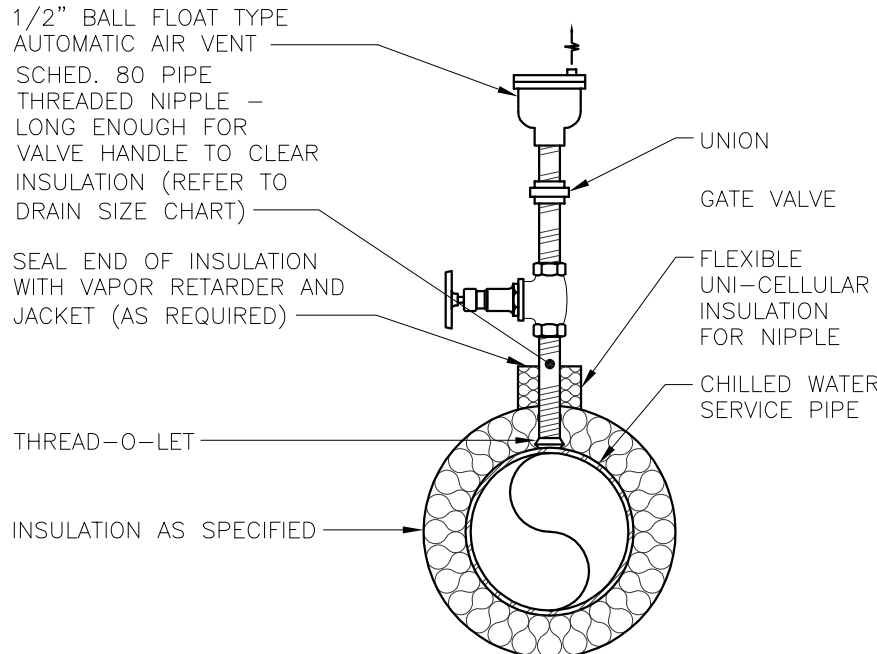

AIR VENT

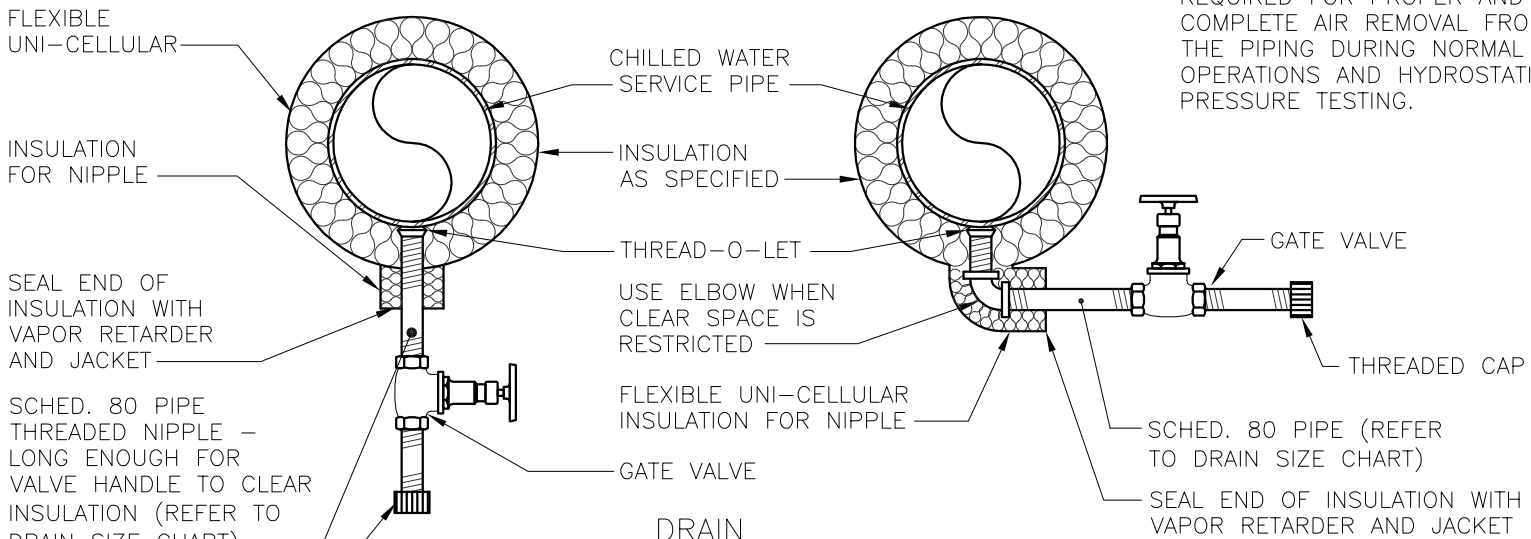

DRAIN

DETAIL CHW-3 - CHILLED WATER DRAIN CONNECTION & AIR VENT

REV 0, 05/29/18

DRAIN SIZE CHART	
PIPE SIZE	DRAIN SIZE
1 1/2" OR LESS	1/2"
2" - 8"	3/4"
10" - 20"	1"
24" - 42"	2"

DETAIL NOTES:

1. PROVIDE DRAINS AT ALL LOW POINTS IN THE PIPING SYSTEM WHERE WATER CAN COLLECT WHEN DRAINING THE PIPING SYSTEM AND OTHER LOCATIONS INDICATED.
2. PROVIDE AIR VENTS AT ALL HIGH POINTS IN THE SYSTEM AS REQUIRED FOR PROPER AND COMPLETE AIR REMOVAL FROM THE PIPING DURING NORMAL OPERATIONS AND HYDROSTATIC PRESSURE TESTING.



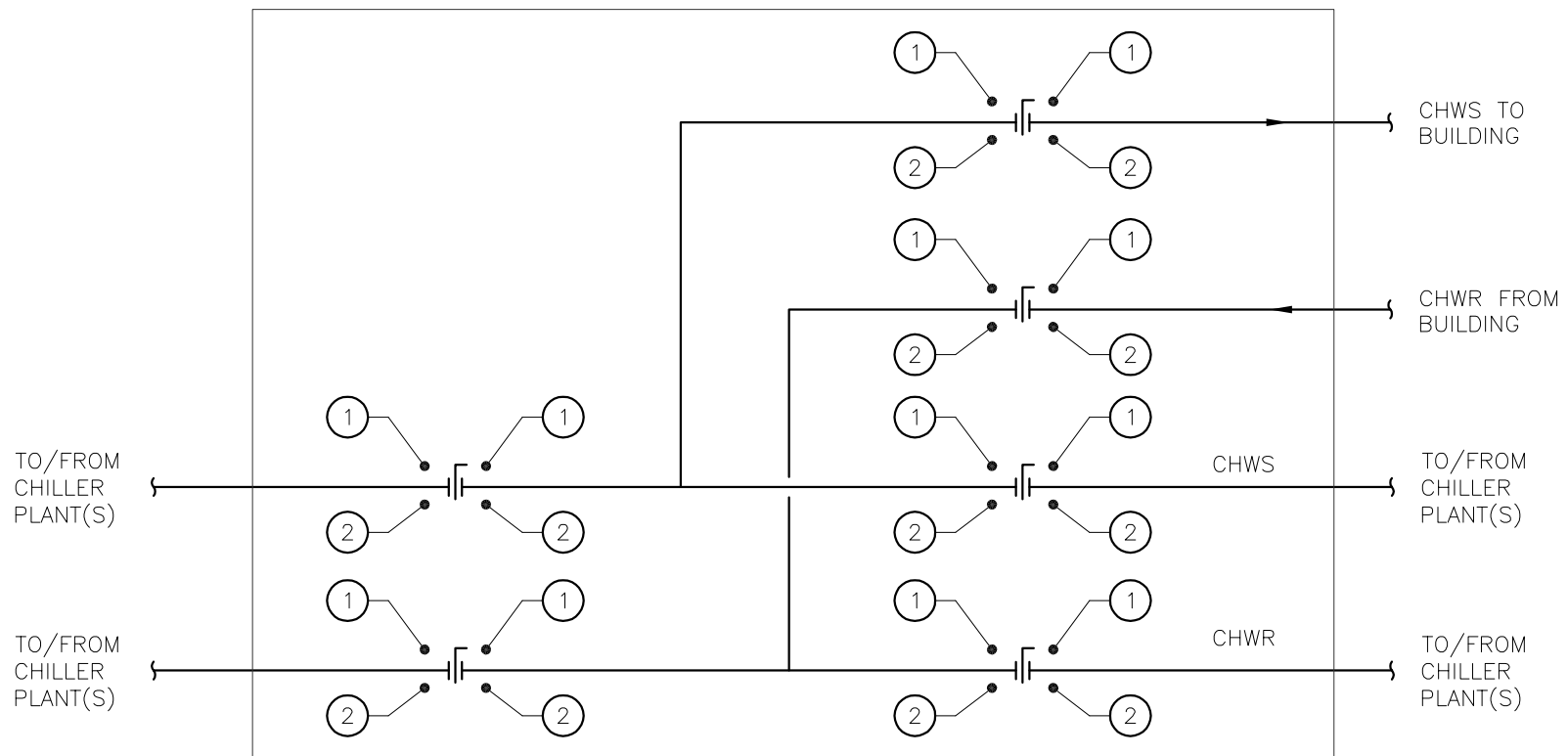

DETAIL NOTES:

1. PROVIDE AUTOMATIC AIR VENTS AT HIGH POINTS ASSUMING ALL VALVES OPEN.

DRAWING NOTES:

- ① PROVIDE 1/2" MANUAL VENT VALVE WITH THREADED CAP AT HIGH POINTS WHERE AIR CAN BE TRAPPED BY CLOSED VALVES IN THE MAIN. SEE DETAIL CHW-3.
- ② PROVIDE MANUAL DRAIN WITH THREADED CAP AT ALL LOW POINTS INCLUDING THOSE CREATED BY CLOSED VALVES IN THE MAINS. SIZE DRAIN PER CHART IN DETAIL CHW-3.

DETAIL CHW-4 – CHILLED WATER MANHOLE
ISOLATION VALVES – BI-DIRECTIONAL FLOW

REV 0, 05/29/18

DETAIL NOTES:

1. PROVIDE CORE DRILL FOR EXISTING STRUCTURES. SIZE CORE DRILLED HOLE FOR PIPE, CONDUIT, AND SEAL.
2. DO NOT STUB INTO HDPE TRANSMISSION PIPE.
3. CARBON STEEL PIPE ONLY IN MANHOLES AND BUILDINGS – NO HDPE.

LINKED WATERTIGHT SEAL ASSEMBLY WITH INSULATING NEOPRENE SEALS, END PRESSURE PLATES AND STAINLESS STEEL TIGHTENING BOLTS AND NUTS. (PROVIDE APPROPRIATE MATERIALS FOR SERVICE PIPE TEMPERATURES)

FIELD FABRICATED OUTER JACKET (6 GAUGE STEEL)

ROUTE VENT TO THE FLOOR

PROVIDE THREADED END FOR CAPPING FOR PRESSURE TESTING

PROVIDE CHECK VALVE IN VERTICAL POSITION

1" VENT

END SEAL

1" ED

PROVIDE CHECK VALVE IN HORIZONTAL POSITION

ROUTE DRAIN TO THE FLOOR. CAP PIPE AFTER TESTING.

6" MIN

6" MIN

INSIDE FACE OF BUILDING OR MANHOLE

WALL THICKNESS

PROVIDE 6 GAUGE STEEL SLEEVE. MATCH OD TO SLEEVE LIP OF HDPE/STEEL TRANSITION PIECE.

ELASTOMERIC SHEET WATERPROOFING

PROVIDE ASPHALTIC WATERPROOFING ALL AROUND INSIDE AND OUT WHERE ELASTOMERIC SHEET WATERPROOFING NOT REQUIRED OR EXISTING

2 STAINLESS STEEL CLAMPS

8" MIN

ASTM A53 OR A106 GRB CARBON STEEL PIPE PER CHILLED WATER PIPE SPEC

PACK W/OAKUM AND CAULK

6 GAUGE STEEL SLEEVE. SIZE FOR SLEEVE, CARRIER PIPE, AND SEAL

LEAK PLATE

EXTERIOR WALL

PROVIDE FOAMGLASS INSULATION, THICKNESS PER PIPING INSULATION THICKNESS CHART. APPLY IN FIELD AND TUCK INTO TRANSITION PIECE LIP. DUE TO CLOSURE WELDS OF CASING, DO NOT USE ANY OTHER INSULATION TYPE.

HDPE TO STEEL WELD-ON TRANSITION ID CONTROLLED WITH FACTORY SUPPLIED STEEL LIP SO SECONDARY CONTAINMENT JACKET CAN BE WELDED. SHALL BE POLY-CAM 863 ID CONTROLLED SPECIAL ORDER OR APPROVED EQUAL.

SLEEVE LIP BY TRANSITION PIECE MANUFACTURER IN LENGTH WARRANTED BY THE MANUFACTURER SO CASING CAN BE BUTTWELDED TO THE END AND NOT DAMAGE HPDE

HPDE TO HDPE FUSION JOINT PER SPEC

HDPE CHILLED WATER PIPE PER SPEC

FIELD BUTTWELD STEEL TO STEEL

FACTORY APPLY EPOXY COATING (POLYCAM IF 194T RED IRON OXIDE) FUSION BONDED TO ASTM A 53 GR B CARBON STEEL PER AWWA C116-01 AND C213-01. FIELD APPLY SAME EPOXY COATING ON ENTIRE EXTERIOR CASING AND HDPE/STEEL SLEEVE LIP PRIOR TO INSTALLING THROUGH WALL, EXCEPT LEAVE 6" FROM FIELD WELDS AND FINISH AFTER WELDING.

DETAIL CHW-5 – HDPE TO STEEL TRANSITION

REV 0, 08/21/18

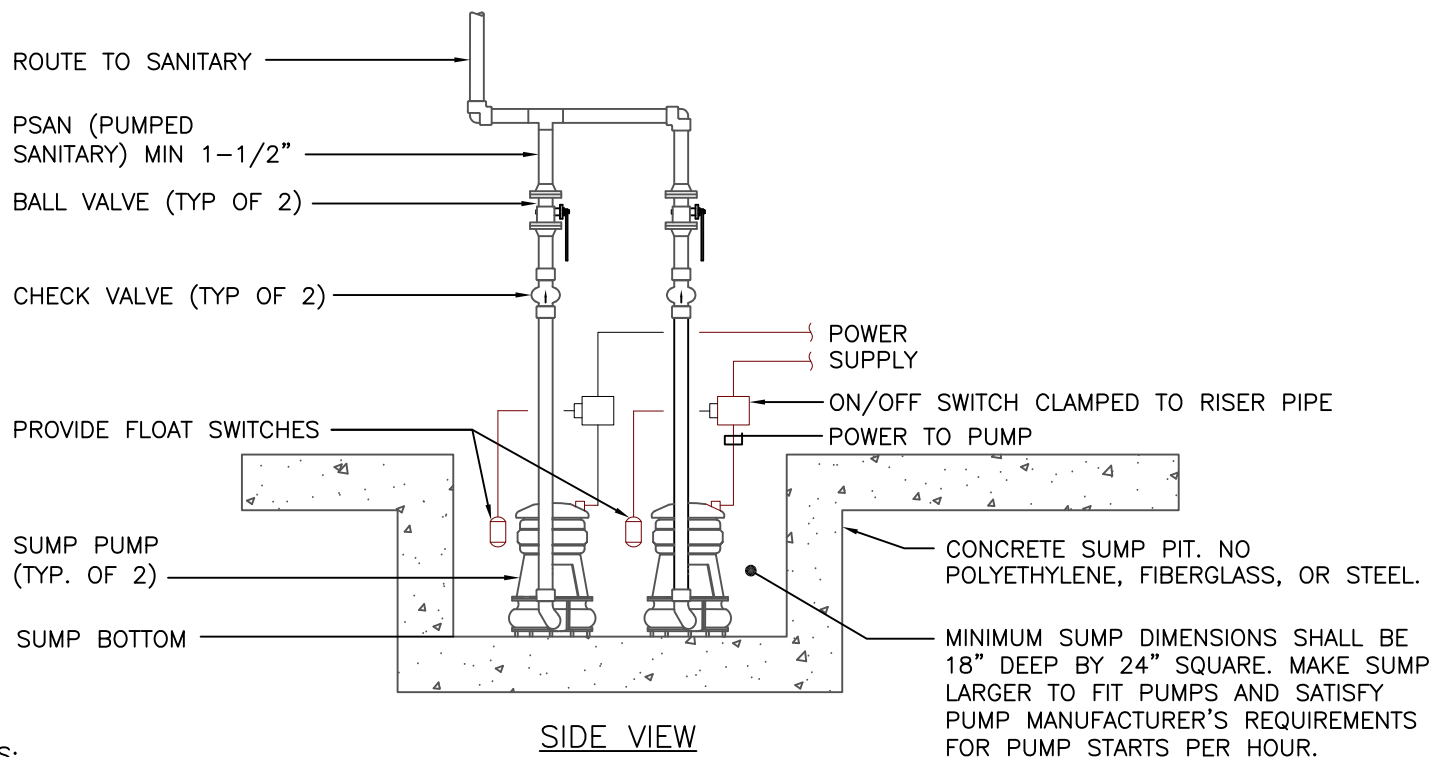

SIDE VIEW

DETAIL NOTES:

1. ELECTRICAL CONDUIT SHALL BE ALUMINUM.
2. PROVIDE FEMALE PIGTAIL TO POWER THE PUMP, NOT A RECEPTACLE.
3. PUMP CAPACITY SHALL BE MINIMUM 25 GPM AND POSSIBLY HIGHER PER FACILITIES HEAD SHALL BE CALCULATED BY ENGINEER CONSIDERING BOTH PUMPS RUNNING AT DESIGN LOAD.
4. PUMP SHALL HAVE 1/2" SOLIDS CAPACITY, PROVIDED WITH FLOAT FOR EACH PUMP MOUNTED ABOVE OPERATING LEVEL ON PUMP DISCHARGE PIPE. ACCEPTABLE MANUFACTURERS INCLUDE BARNES, GOULDS, LITTLE GIANT, AND ZOELLER.
5. PREFERRED TO HAVE 1/2 HP, 1 PH, 120V SERVICE BUT MAY BE 1/2 HP, 1 PH, 230V SERVICE TO ACCOMMODATE LONG POWER RUNS.
6. CONSULTANT TO DISCUSS WITH FACILITIES SERVICES OPTIONS TO INSTALL LIGHTS IN MANHOLES WHERE AN ELECTRIC SUMP PUMP IS USED.

DETAIL CHW-6 - SUMP PUMP - ELECTRIC POWERED

REV 0, 12/17/20

ROTATION ARROWS
 THESE INDICATE ROTATION TO CLOSE
 VALVE. 2 TO 6 ARROWS THAT ARE IN
 CIRCULAR PATTERN AROUND
 PERIMETER OF DISK. SHOULD NOT
 INTERFERE WITH LETTERING OR BE
 HIDDEN BY ANCHORING PINS.

VALVE TYPE
 GV = GATE VALVE
 BF = BUTTERFLY VALVE

VALVE
 SIZE

VALVE IDENTIFIER

DEFAULT VALVE
 POSITION
 NO = NORMALLY OPEN
 NC = NORMALLY CLOSED

UF ASSET
 NUMBER
 PROVIDED BY
 UF FS UTILITIES

DIRECTION TO TURN
 VALVE TO CLOSE IT
 RT = RIGHT TURN
 LT = LEFT TURN

DETAIL A

NUMBER OF ROTATIONS
 TO CLOSE VALVE

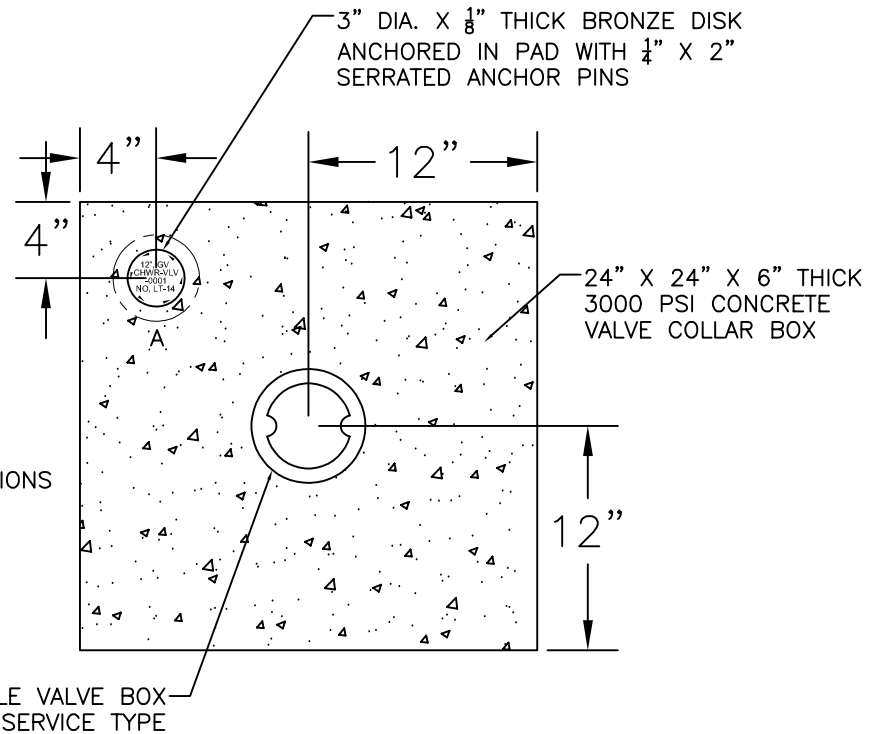

APPLICABLE VALVE BOX
 PER SERVICE TYPE

DETAIL NOTES:

1. LETTERING TO BE $\frac{5}{16}$ " TALL MINIMUM

DETAIL CHW-7 – DIRECT BURIED VALVE IDENTIFIER

REV 0, 05/26/21

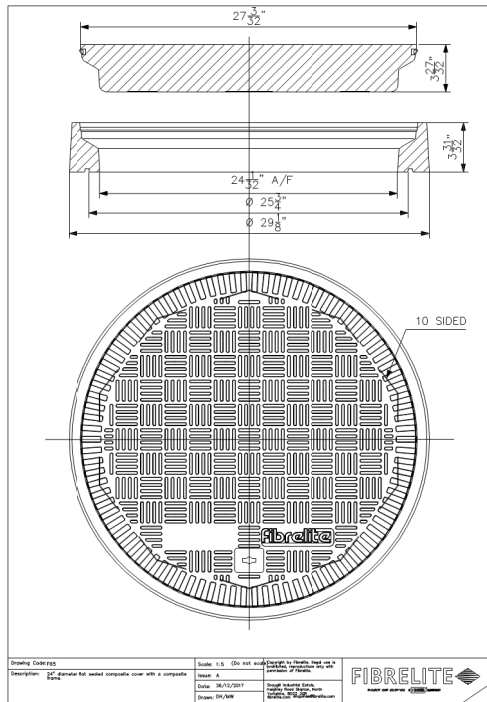

CONCRETE

VERY IMPORTANT
FRAMES MUST BE INSTALLED FLUSH WITH FINISHED GRADE OR SET SLIGHTLY BELOW FINISHED GRADE TO PROTECT FROM SNOWPLOW DAMAGE

VERY IMPORTANT
To allow for drainage, Fibrelite recommends that the concrete be sloped away from the top outer edge of the frame (A) a minimum of 1/2" over a 12" distance. Do not expose the top outer edge of the frame (A) – the concrete pad must be flush with the top outer edge of the frame.

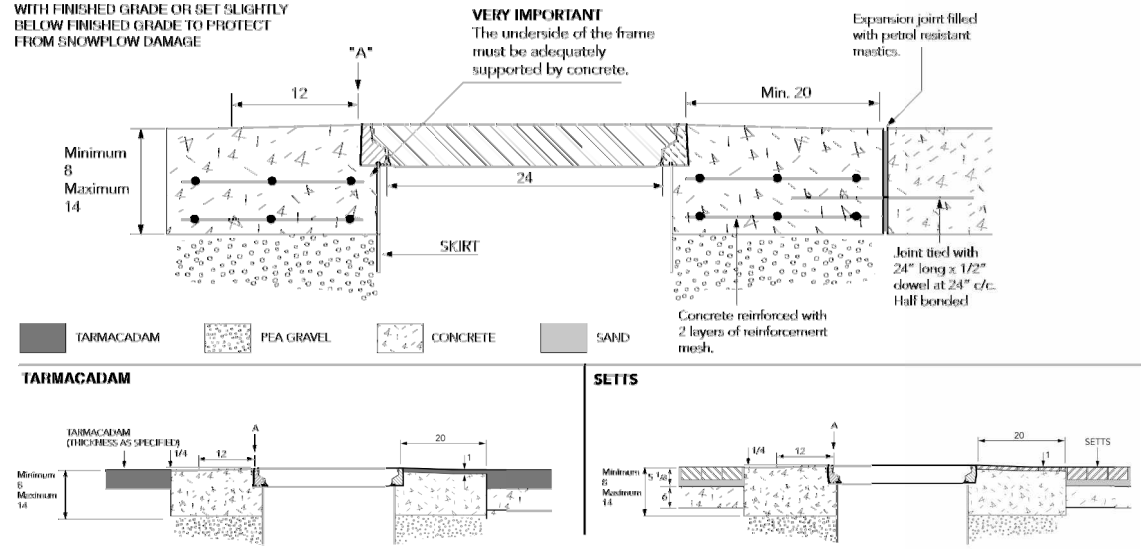

DETAIL NOTE:

1. PROVIDE DIAMETER OF MANHOLE LID PER OTHER DETAILS.

DETAIL MH-1 – FIBRELITE MANHOLE FRAME AND COVER

REV 0, 05/29/18



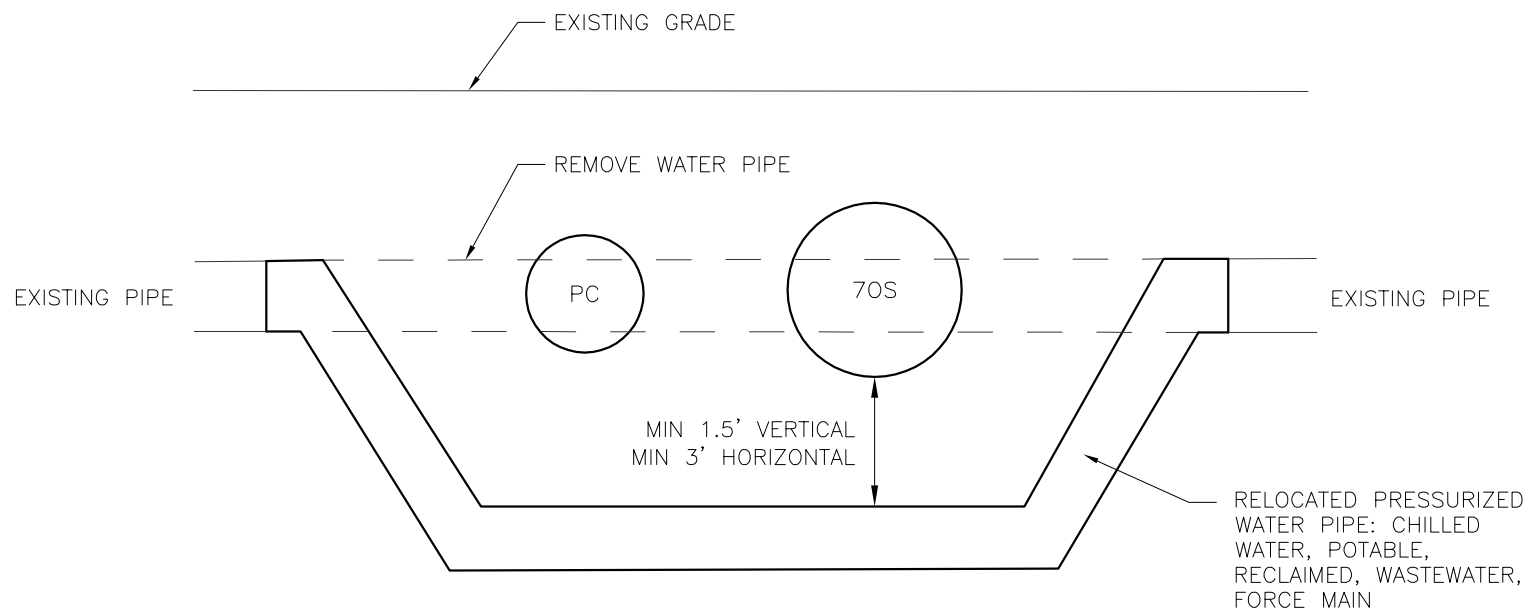

DETAIL NOTE:

1. MOVE EXISTING PIPES AWAY FROM DIRECT BURIED STEAM AND CONDENSATE PIPING.
2. DISCUSS WITH FACILITIES SERVICES WHEN MINIMUMS CANNOT BE MAINTAINED DUE TO EXISTING CONDITIONS OR EXTENUATING CIRCUMSTANCES.

DETAIL MH-2 – MINIMUM DISTANCE TO UTILITIES

REV 0, 05/29/18

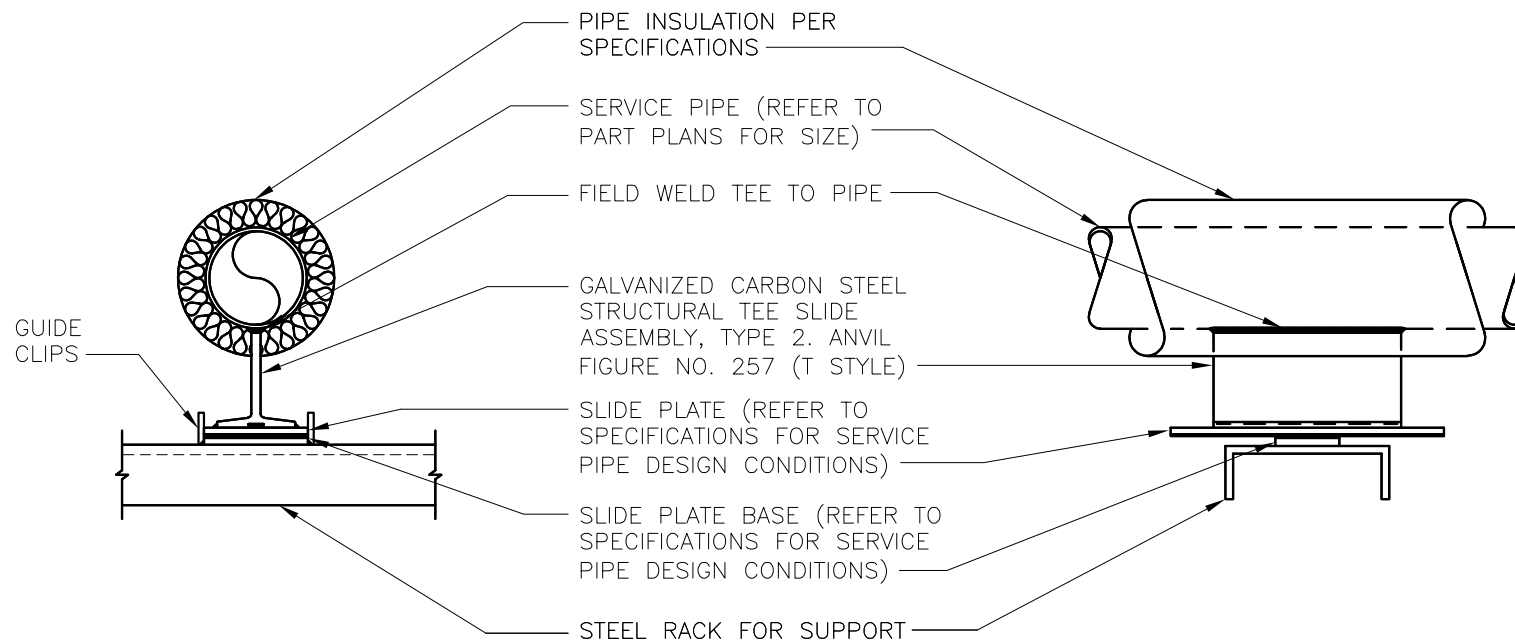

DETAIL NOTES:

1. THIS SUPPORT IS TYPICAL FOR A TUNNEL WHERE THERE ARE EXPANSION LOOPS WITH NON-AXIAL MOVEMENT OR EXPANSION JOINTS. USE THIS DETAIL FOR MANHOLES WITH EXPANSION LOOPS OR EXPANSION JOINTS AND REPLACE STEEL BASE WITH CONCRETE BASE.
2. FOR NEW CONSTRUCTION, ELEVATION OF STEEL RACKS SHALL BE VERIFIED TO ENSURE PIPE SLOPE.
3. FOR EXISTING CONSTRUCTION, PROVIDE ABILITY FOR VARYING SUPPORT HEIGHT.

DETAIL MH-3 – PIPE GUIDE SUPPORT

REV 1, 03/29/19

PIPE INSULATION PER SPECIFICATIONS

SERVICE PIPE (REFER TO PLANS FOR SIZE)

SADDLE FOR SUPPORT

GALVANIZED CARBON STEEL ADJUSTABLE PIPE ROLL SUPPORT, ANVIL FIGURE NO. 177

2" THICK GROUT PAD

CONCRETE FLOOR OF TUNNEL OR MANHOLE

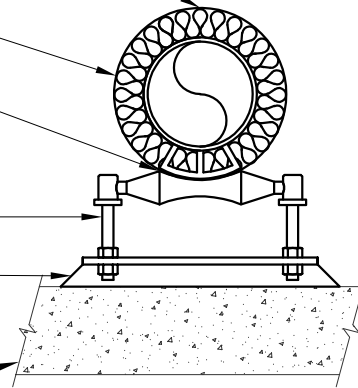

DETAIL MH-4 - PIPE ROLLER SUPPORT

REV 1, 03/29/19

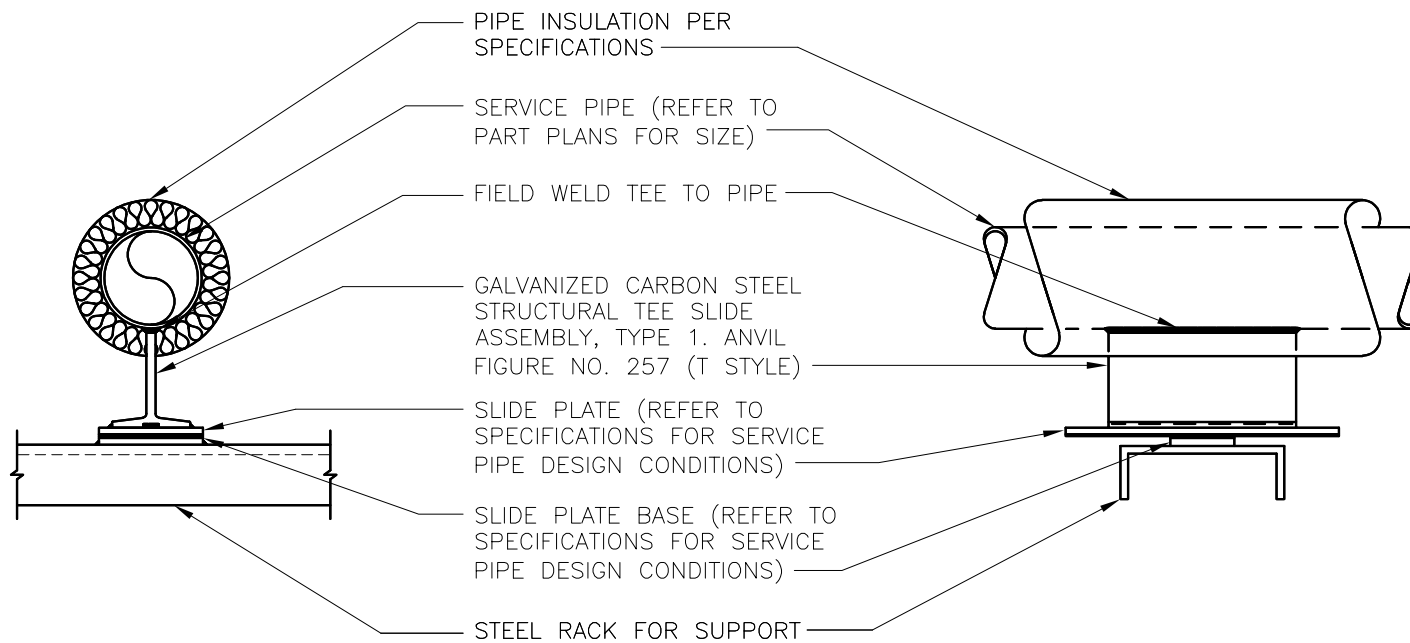

DETAIL NOTES:

1. THIS SUPPORT IS TYPICAL FOR A TUNNEL WHERE THERE ARE EXPANSION LOOPS WITH NON-AXIAL MOVEMENT. USE THIS DETAIL FOR MANHOLES WITH EXPANSION LOOPS AND REPLACE STEEL BASE WITH CONCRETE BASE.
2. FOR NEW CONSTRUCTION, ELEVATION OF STEEL RACKS SHALL BE VERIFIED TO ENSURE PIPE SLOPE.
3. FOR EXISTING CONSTRUCTION, PROVIDE ABILITY FOR VARYING SUPPORT HEIGHT.

DETAIL MH-5 – PIPE SLIDE SUPPORT

REV 1, 03/29/19

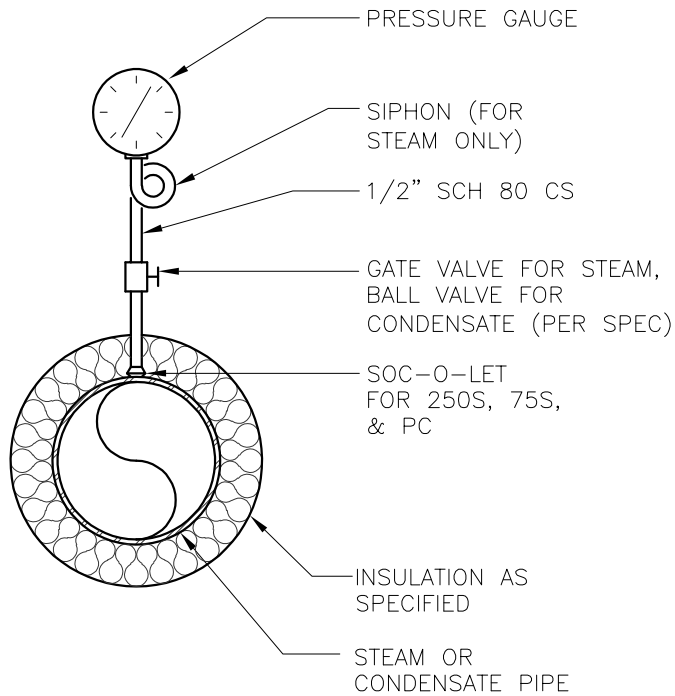

STEAM AND CONDENSATE

DETAIL NOTES:

1. PROVIDE STEAM AND CONDENSATE PRESSURE GAUGES WHERE REQUESTED BY FACILITIES SERVICES.
2. INSTALL STEAM AND CONDENSATE PIPE PRESSURE GAUGES AT ACCESSIBLE AND READABLE LOCATIONS AND POSITIONS APPROVED BY FACILITIES SERVICES.

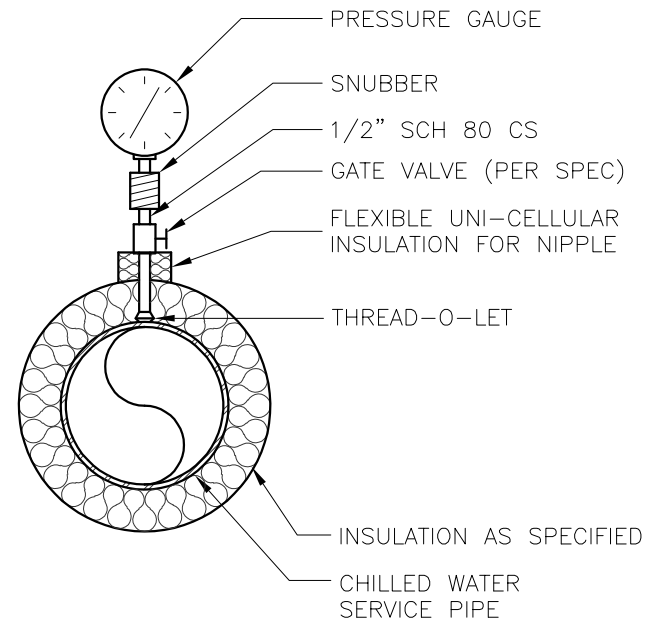

CHILLED WATER

DETAIL NOTES:

1. PROVIDE CHILLED WATER PRESSURE GAUGES WHERE REQUESTED BY FACILITIES.
2. INSTALL CHILLED WATER SUPPLY AND RETURN PIPE PRESSURE GAUGES AT ACCESSIBLE AND READABLE LOCATIONS AND POSITIONS APPROVED BY FACILITIES SERVICES.

DETAIL MH-6 – PRESSURE GAUGES

REV 1, 03/29/19

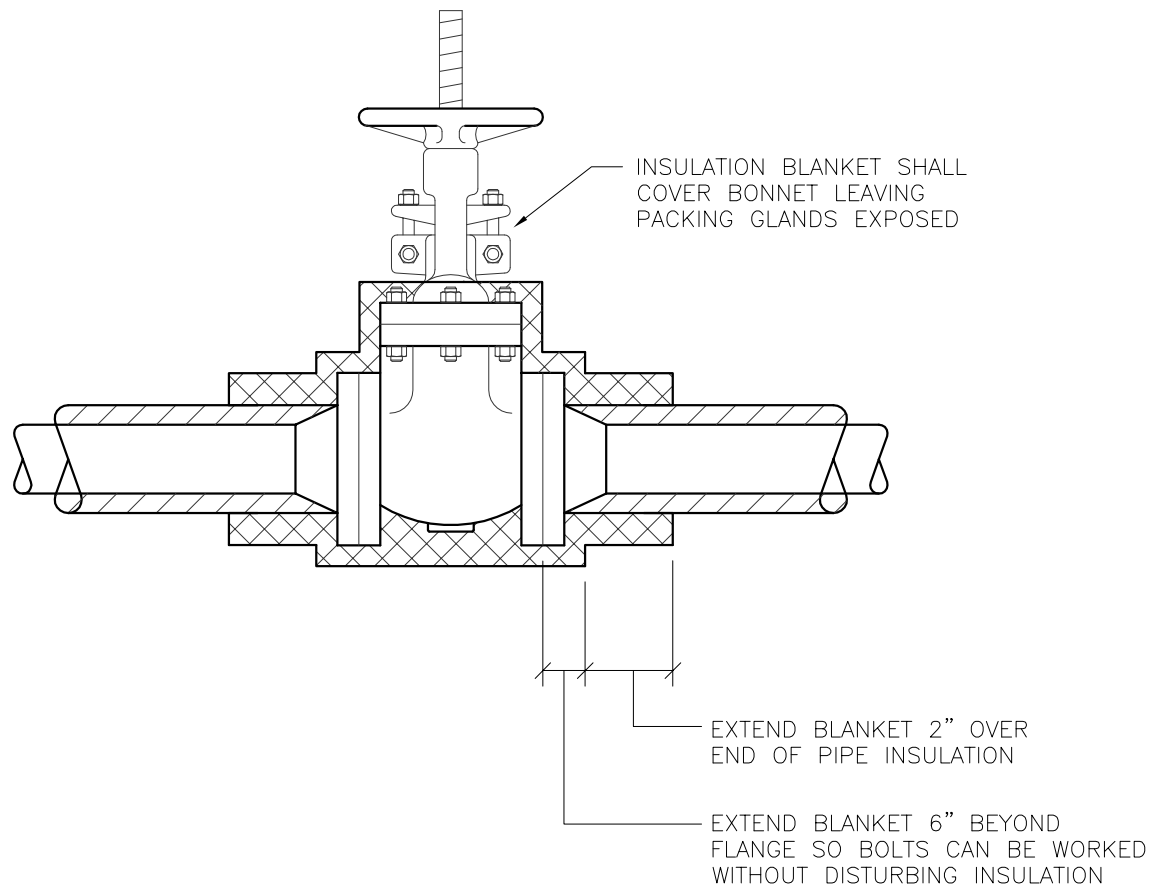

DETAIL NOTES:

1. PROVIDE INSULATION BLANKETS FOR ALL STEAM, PC, AND CHILLED WATER FLANGED VALVES.
2. USE WEAVED WIRE FASTENERS TO SECURE INSULATION BLANKETS.
3. REFER TO SPEC FOR ADDITIONAL REQUIREMENTS.

DETAIL MH-7 – VALVE INSULATION BLANKETS

REV 0, 05/29/18

DETAIL NOTES:

1. PROVIDE CORE DRILL FOR EXISTING STRUCTURES. SIZE CORE DRILLED HOLE FOR CARRIER PIPE AND SEAL.
2. GLAND AND END SEALS SHALL BE PRE-FABRICATED BY UNDERGROUND DISTRIBUTION PIPING SYSTEM MANUFACTURER.
3. VENT AND ED PIPING SHALL MATCH PC PIPING SPECIFICATIONS. CHECK VALVES SHALL BE IN ACCORDANCE WITH THE "PC" SYSTEM SPECIFICATION.
4. NOTE TO CONTRACTOR: VENT AND ED COMPONENTS ARE USUALLY NOT PROVIDED WITH DIRECT BURIED SYSTEMS.
5. FOR P-SAN, STORM DRAIN, AND HIGH/LOW VENT PENETRATIONS IN NEW MANHOLES, PROVIDE 6 GAUGE STEEL SLEEVE SIZED FOR SLEEVE, SERVICE PIPE, AND SEAL. IN EXISTING MANHOLES, CORE DRILL OPENING FOR SERVICE PIPE AND SEAL (NO STEEL SLEEVE).

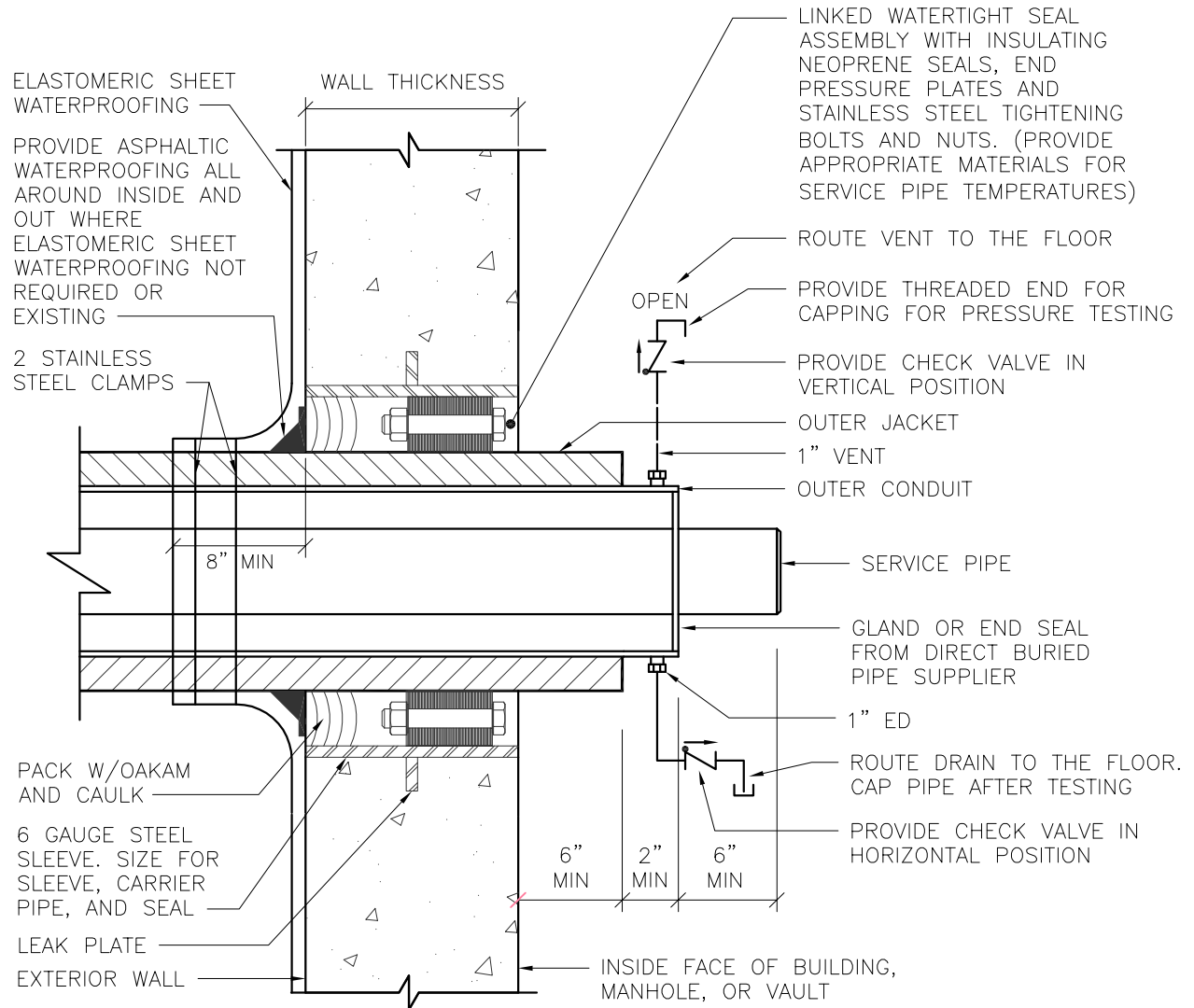

DETAIL MH-8 - WALL PENETRATION

REV 0, 05/29/18

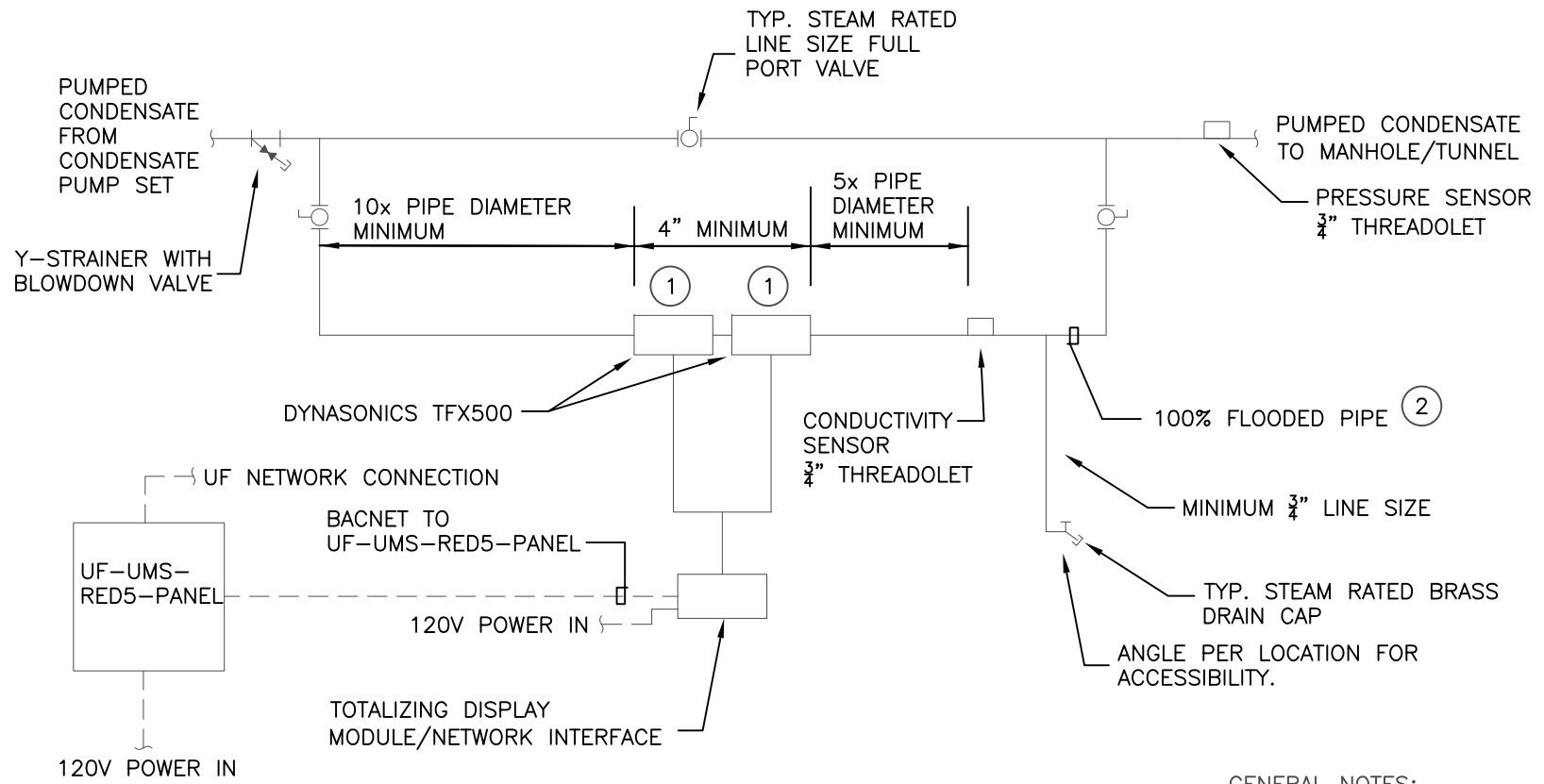

DRAWING NOTES:

- ① FINAL METER SELECTION MUST BE APPROVED IN WRITING BY FACILITIES SERVICES METERING GROUP.
- ② IT IS CRITICAL THAT THIS SECTION OF PIPE STAYS FLOODED AT ALL TIMES FOR PROPER OPERATION OF CONDUCTIVITY PROBE AND FLOW METER

GENERAL NOTES:

FLOW METER INTERFACE OUTPUT VOLUME FLOW (TOTAL GAL) AND FLOW RATE (GPM) OVER BACNET. ULTRASONIC METER SHALL BE DYNASONICS MODEL TFX500.

**DETAIL STM-1 – BUILDING PUMPED
CONDENSATE FLOW METER**

REV 1, 03/2024

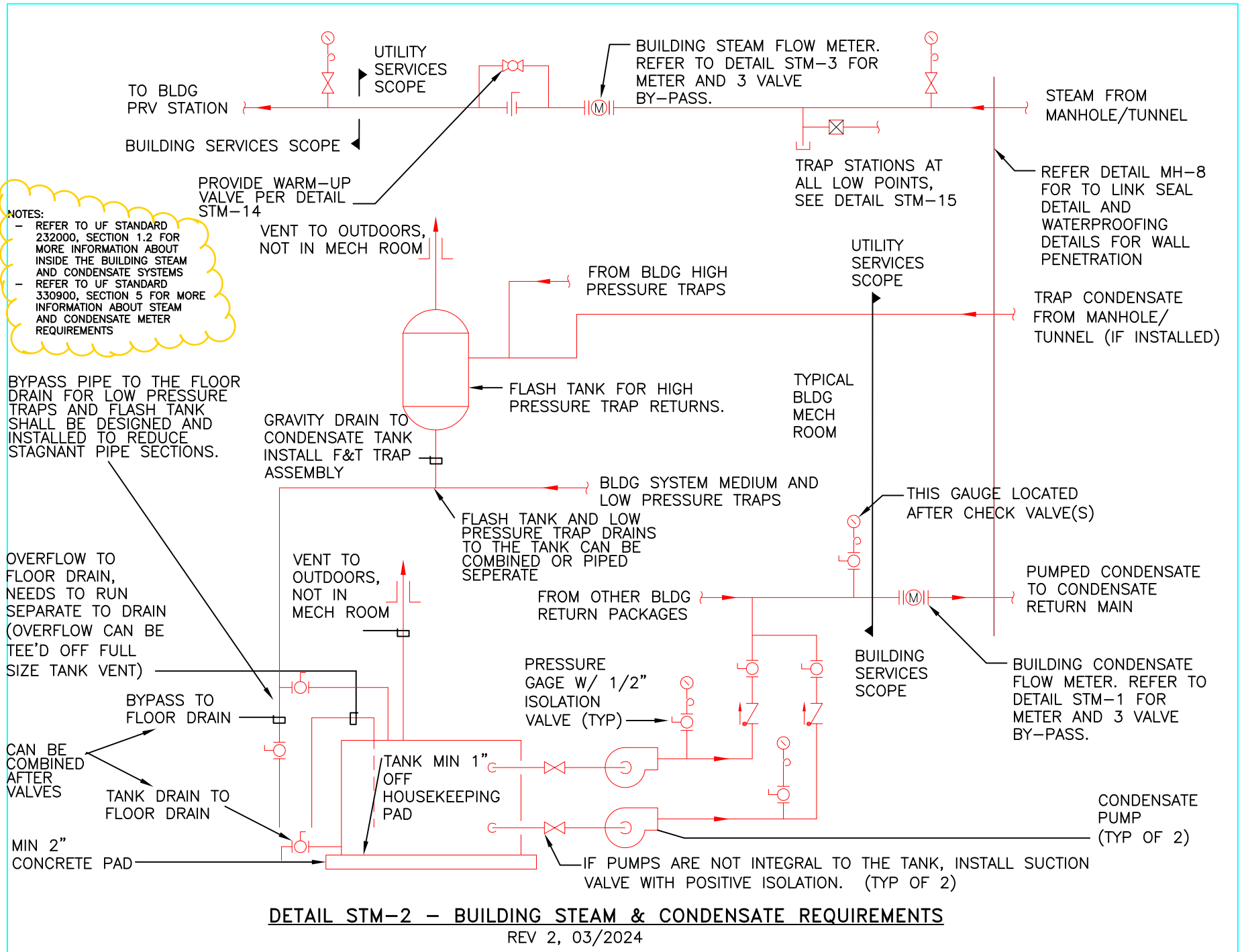

INLINE VORTEX STEAM FLOW METER RANGES TO DETERMINE METER BODY SIZE	
STEAM FLOW RANGE (PPH)	FLOW METER SIZE (NPS INCHES)
34–191	1/2
46–521	3/4
60–841	1
95–2,556	1–1/2
231–4,271	2
535–10,692	3
920–18,411	4
2,089–41,782	6
3,617–72,350	8
5,700–114,000	10

FLOW METER SHALL OUTPUT MASS FLOW AND PRESSURE OVER BACNET AND SHALL PROVIDE INTERNAL COMPENSATION FOR PRESSURE AND TEMPERATURE. PROVIDE ARMSTRONG MODEL AVF, CLASS ISO FLANGED.

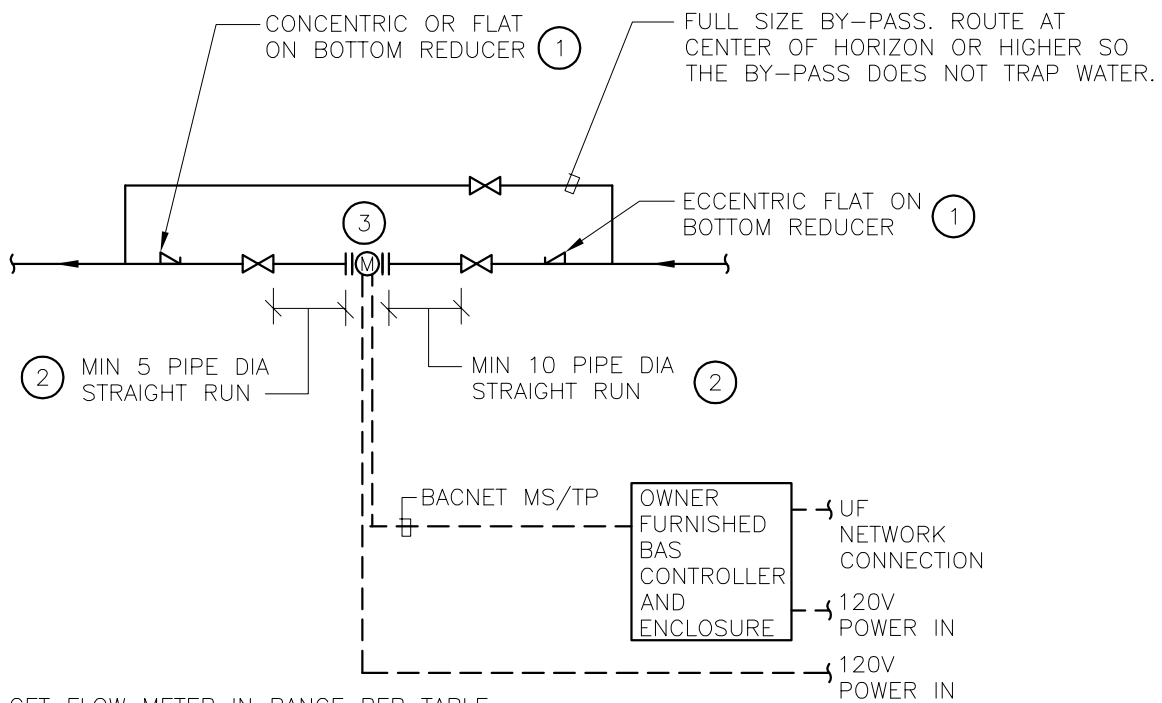

DETAIL NOTES:

1. REFER TO DETAIL STM-2 FOR LOCATION OF METER.
2. VALUES BASED ON STEAM AT 70 PSIG, 335 DEG F.

DRAWING NOTES:

- (1) PROVIDE REDUCERS WHEN NECESSARY TO GET FLOW METER IN RANGE PER TABLE.
- (2) PROVIDE FLOW METER STRAIGHTENER FROM FLOW METER MANUFACTURER IF UPSTREAM/DOWNSTREAM STRAIGHT RUNS ARE NOT AVAILABLE.
- (3) FINAL METER SELECTION MUST BE APPROVED BY FACILITIES SERVICES.

DETAIL STM-3 – BUILDING STEAM FLOW METERS
REV 0, 05/29/18



ELASTOMERIC SHEET WATERPROOFING
 PACK WITH OAKUM AND CAULK
 PROVIDE ASPHALTIC
 WATERPROOFING ALL AROUND
 2 STAINLESS STEEL CLAMPS
 PITTPWRAP HS JACKETING
 SEE SPECIFICATIONS FOR
 WELDING REQUIREMENTS
 AEROGEL INSULATION

FOR PIPING THAT IS
 THERMALLY GROWING INTO
 AN EXPANSION JOINT IN THE
 MANHOLE, PROVIDE CONDUIT
 SPLIT GLAND SEAL PER
 DIRECT BURIED PIPE SYSTEM
 MANUFACTURER'S
 REQUIREMENTS. FOR PIPE
 ANCHORED IN MANHOLE,
 REFER TO DETAIL
 "CONNECTION OF NEW DIRECT
 BURIED PIPING TO EXISTING".

FOAMGLAS
 INSULATION
 EXISTING
 STEAM PIPE
 EXISTING PIPE CONDUIT
 EXISTING INSULATION
 6" MIN. OVERLAP

EXISTING STEAM OR
 CONDENSATE PIPE
 NEW
 STEAM OR
 CONDENSATE
 PIPE

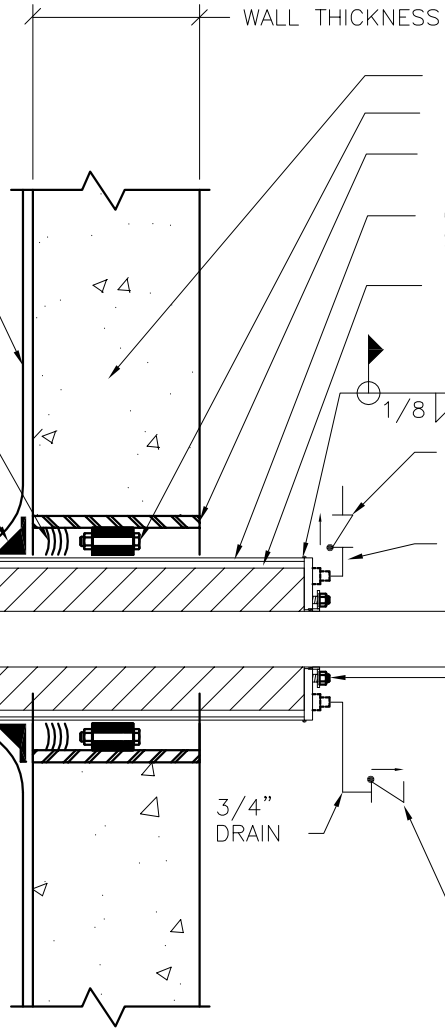

MANHOLE WALL
 HIGH TEMPERATURE LINK SEAL
 PRE-CAST VAULT
 WALL PENETRATION
 6 GAUGE STEEL SLEEVE. SIZE FOR
 SLEEVE, CARRIER PIPE, AND SEAL
 FOAMGLAS INSULATION
 3/4" PC SYSTEM
 CHECK VALVE
 3/4" VENT
 NEW PIPE
 PROVIDE FIELD APPLIED
 CONDUIT SPLIT GLAND SEAL PER
 DIRECT BURIED MANUFACTURER'S
 REQUIREMENTS WHERE PIPE
 THERMALLY GROWS INTO AN
 EXPANSION JOINT IN THE
 MANHOLE. FOR PIPE ANCHORED
 IN MANHOLE OR JUST OUTSIDE,
 PROVIDE END SEAL.
 3/4" PC SYSTEM
 CHECK VALVE

**DETAIL STM-4 – CONNECTION OF EXISTING DIRECT
 BURIED PIPING TO REHAB STEAM MANHOLE**

REV 0, 05/29/18



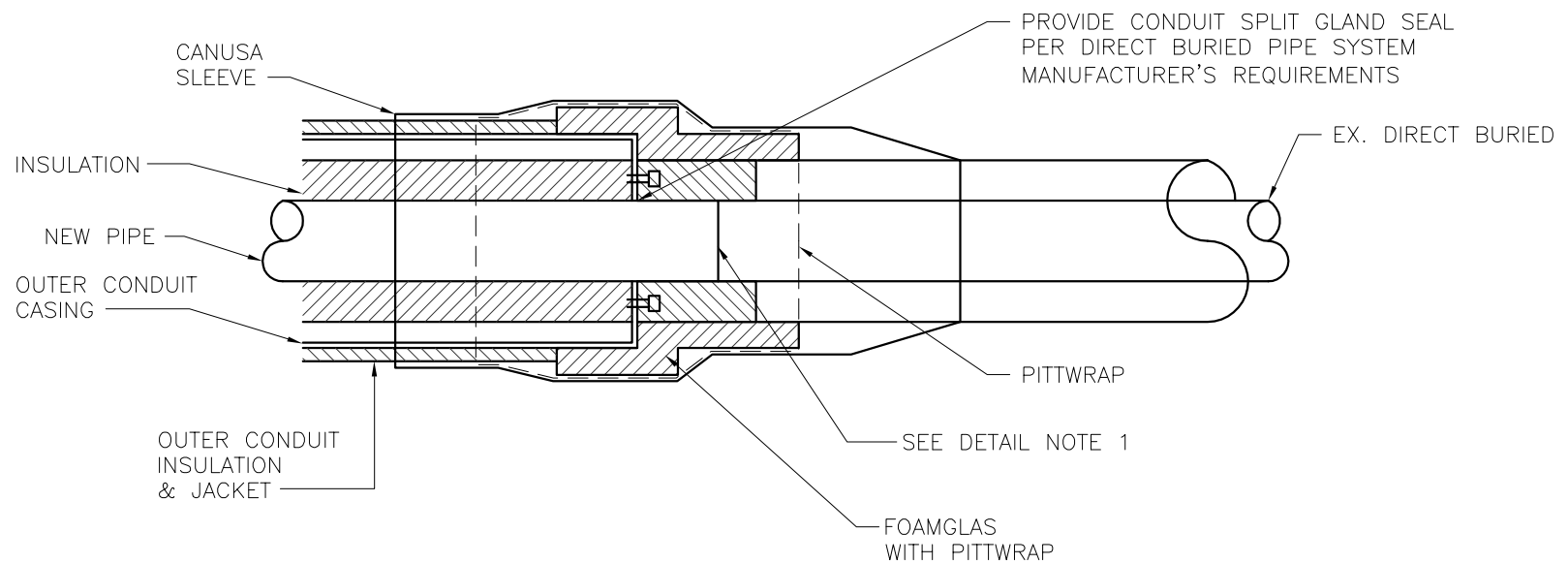

DETAIL NOTE:

1. SEE SPECIFICATION FOR WELDING REQUIREMENTS.

DETAIL STM-5 – CONNECTION OF NEW DIRECT BURIED PIPE TO EXISTING BEYOND MANHOLE

REV 0, 05/29/18

DETAIL NOTE:

1. ALL SEWER CONNECTIONS SHALL BE DONE IN ACCORDANCE WITH THE FOLLOWING INSTRUCTIONS OR AS DIRECTED BY THE LOCAL AUTHORITY: CORE DRILL HOLES IN EXISTING SANITARY SEWER MANHOLES AT ELEVATIONS INDICATED. CONTRACTOR SHALL EXTEND STAINLESS STEEL LINE THROUGH HOLE INTO THE EXISTING SANITARY SEWER MANHOLE AND PROVIDE A FLANGE AND A TEE TURNED IN THE VERTICAL DIRECTION. THE STAINLESS STEEL LINE SHALL EXTEND UP ONE FOOT ABOVE THE TEE WITH END LEFT OPEN. THE STAINLESS STEEL LINE SHALL ALSO EXTEND FROM THE TEE DOWN THE SIDE OF THE MANHOLE. AT THE BOTTOM OF THE MANHOLE A 45 DEGREE BEND SHALL BE INSTALLED, ROTATED TO LINE UP IN THE DIRECTION OF FLOW. THE STAINLESS STEEL PIPE EXTENDING DOWN THE SIDE OF THE MANHOLE SHALL BE FASTENED TO THE SIDE OF THE MANHOLE WITH STAINLESS STEEL PIPE CLAMPS, 3" STAINLESS STEEL BOLTS DRILLED, AND EPOXY INTO THE WALLS. THE MAXIMUM SPACING BETWEEN CLAMPS SHALL BE 5 FEET WITH TWO MINIMUM CLAMPS FOR EACH PIPE. THE PIPE PENETRATION THROUGH THE MANHOLE WALL SHALL BE SEALED NON-SHRINK GROUT WITH BENTONITE OR SEALED WITH HYDRO-CEMENT. CONTRACTOR SHALL COORDINATE THE PLACEMENT OF THE INTERIOR STAINLESS STEEL LINE NOT TO INTERFERE WITH EXISTING MANHOLE STEPS.

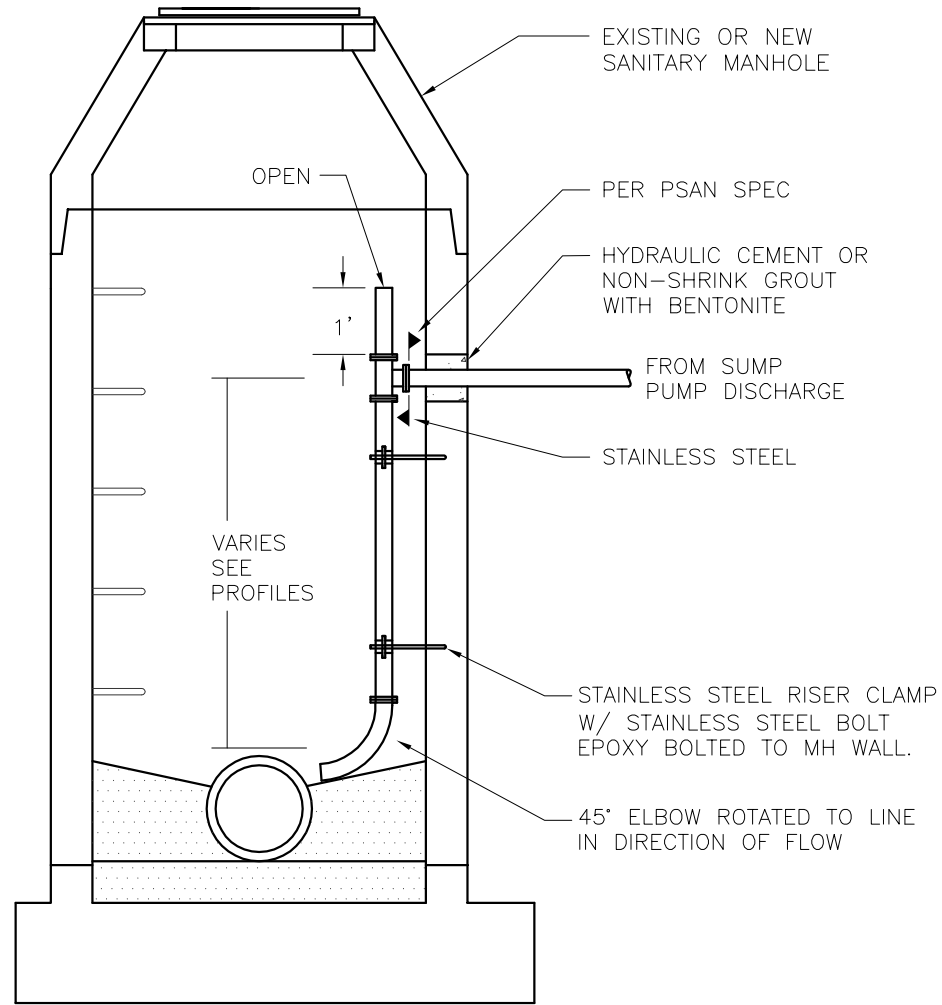

DETAIL STM-6 – PSAN DROP IN SANITARY MANHOLE

REV 0, 05/29/18

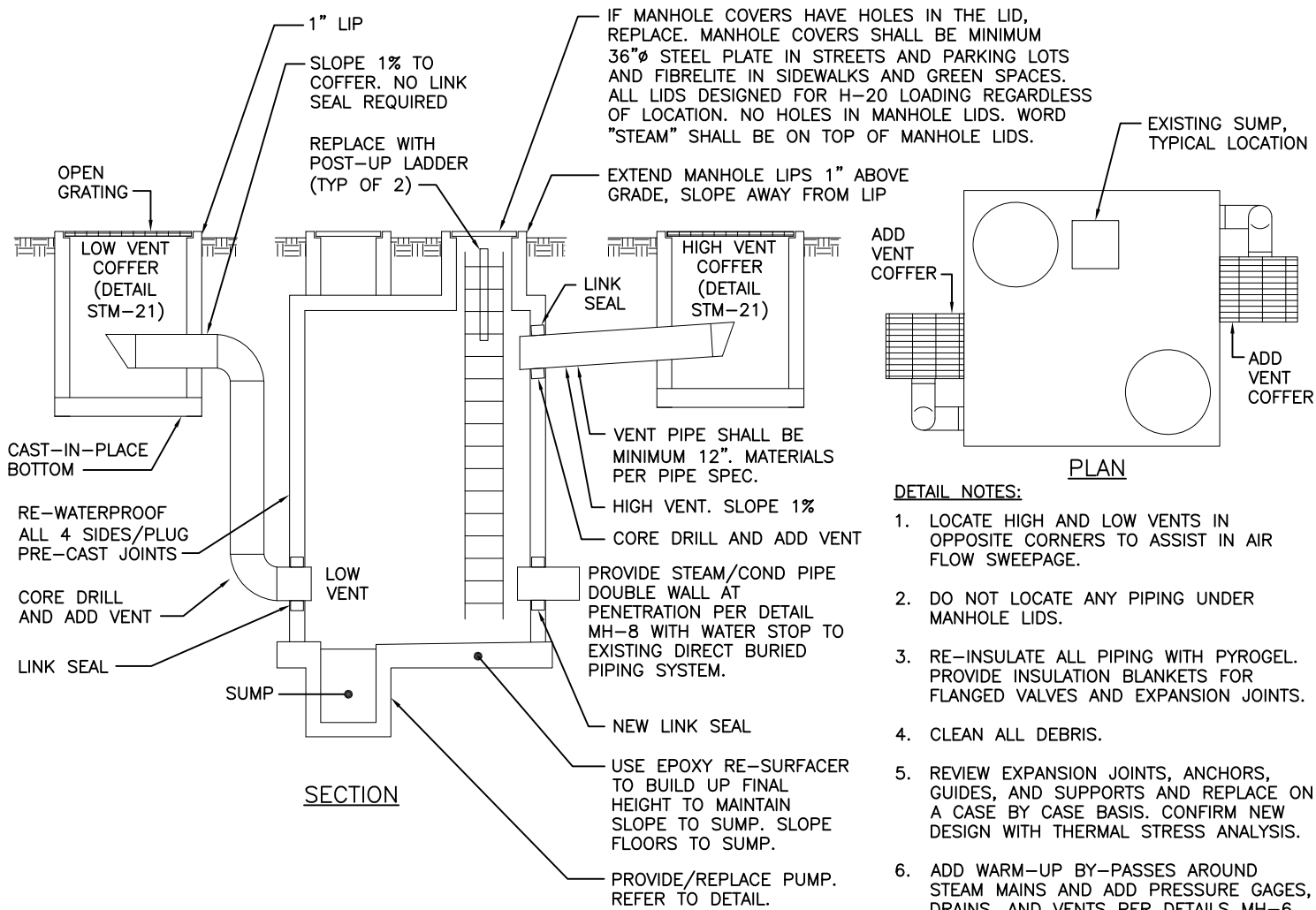

DETAIL STM-7 – REHAB STEAM MANHOLE

REV 1, 07/12/19

DESIGN CONDITIONS FROM PIPE SPEC

USE THIS DESIGNATION FOR ALL EXPANSION JOINTS. START AT "01" IN EACH MH/BLDG/TUNNEL

LIST LOCATION OF XJ

LIST WHERE THE THERMAL EXPANSION IS COMING FROM

SINCE DESIGN TEMP IS USED, ONLY NEED 0.5" MARGIN

IN RARE CASES, USE FOR CHILLED WATER

CALCULATED FROM (DESIGN TEST PRESSURE * DESIGN PRESSURE THRUST AREA)

CALCULATED FROM (DESIGN PRESSURE * DESIGN PRESSURE THRUST AREA) + (DESIGN SPRING RATE * CALCULATED COMPRESSION) + (PIPE SUPPORT FRICTION * DISTANCE BETWEEN ANCHORS/100)

IN-LINE SHALL BE EXTERNALLY PRESSURIZED UNLESS FACILITIES SERVICES DIRECTS OTHERWISE

EXPANSION JOINT SCHEDULE

DESIGNATION	LOCATION	EXPANSION TOPROW	PIPE SIZE & SERVICE (NPS)	NORMAL OPERATING CONDITIONS		DESIGN CONDITIONS				DISTANCE BETWEEN ANCHORS (FT)	EXPANSION JOINT MOVEMENT						EXPANSION JOINT DESIGN DATA				PIPE SUPPORT FRICTION (LBS/100 FT)	TOTAL OPERATING EXPANSION JOINT FORCE (LBS)	TOTAL HYDRO EXPANSION JOINT FORCE (LBS)	NOTES
				PRESSURE (PSI)	OPERATING TEMP (°F)	DESIGN PRESSURE (PSI)	DESIGN TEMP (°F)	INSTALL TEMP (°F)	HYDROSTATIC TEST PRESSURE (PSIG)		CALCULATED			RATED			STYLE	DESIGN PRESS THRUST AREA (SQ IN)	DESIGN SPRING RATE (LBS/IN)	DESIGN PACKING FRICTION RATE (LBS)				
											EXTENSION (IN)	COMPRESSION (IN)	ROTATION (DEG)	EXTENSION (IN)	COMPRESSION (IN)	ROTATION (DEG)								
XJ-01	MH-3C1-2	MH-3C1-1	6" 70S	70	335	90	474	50	135	225	---	7.4	---	-1	8	---	EXTERNALLY PRESSURIZED	52	285	0	890	8,789	7,920	
XJ-02	MH-3C1-2	MH-3C1-1	2" PC	30	180	75	250	50	112.5	225	---	3.5	---	-1	4	---	EXTERNALLY PRESSURIZED	12	194	0	270	2,187	1,350	
XJ-03	MH-3C1-2	MH-3C1-3	6" 70S	70	335	90	474	50	135	150	---	5.0	---	-1	8	---	EXTERNALLY PRESSURIZED	52	380	0	890	7,900	7,020	
XJ-04	MH-3C1-2	MH-3C1-3	2" PC	30	180	75	250	50	112.5	150	---	2.3	---	-1	4	---	EXTERNALLY PRESSURIZED	12	194	0	270	1,751	1,350	
XJ-01	BLDG 123	MH-3C1-1	8" 70S	70	335	90	474	50	135	80	---	2.6	---	-1	4	---	EXTERNALLY PRESSURIZED	83	1212	0	1275	11,641	11,205	
XJ-02	BLDG 123	MH-3C1-1	3" PC	30	180	75	250	50	112.5	80	---	1.2	---	-1	4	---	EXTERNALLY PRESSURIZED	16	252	0	485	1,890	1,800	

NOTES:
1. REMOVE SHIPPING BARS AFTER THE EXPANSION JOINT IS ATTACHED TO PIPE AND ALL PIPE TO ADJACENT ANCHORS IS WELDED INCLUDING THE ANCHORS THEMSELVES.

LIST NORMAL OPERATING CONDITIONS FROM PIPE SPEC. THIS DATA IS FOR INFO ONLY AND IS NOT TO BE USED FOR ANY CALCULATIONS/SELECTIONS ASSOCIATED WITH THE EXPANSION JOINTS.

REQUIRE THIS AS A STANDARD FOR STEAM & CONDENSATE

IF USING BALL JOINTS

ONLY USE LOWER TEMP IF AMBIENT AIR IS LOWER AT INSTALL

FROM EXPANSION JOINT BOB MANUFACTURER

MAKE SURE THIS NUMBER ACCOUNTS FOR NUMBER OF PLYS

FOR SLIP AND BALL JOINTS

USE FOR ALL JOINTS. GOOD TYPICAL NUMBERS ARE FOUND IN ATS SLIP JOINTS CATALOG

DETAIL STM-8 – SCHEDULE – EXPANSION JOINTS

REV 0, 05/29/18



FLOW METERS SCHEDULE

FLOW METER DESIGNATION	FLOW METER LOCATION	SERVICE	FLOW			PIPE SIZE UPSTREAM/DOWNSTREAM OF METER (NPS)	PIPE SIZE AT THE METER (NPS)	PRESSURE		TEMPERATURE		FLOW METER STYLE	END CONNECTIONS	BASIS OF DESIGN
			MINIMUM	NORMAL	MAXIMUM			OPERATING (PSIG)	DESIGN (PSIG)	OPERATING (DEG F)	DESIGN (DEG F)			
FE-70S-1	BLDG 101 MECH RM	70S	750 PPH	6,500 PPH	8,000 PPH	6"	4"	70	90	335	474	VORTEX	CLASS 150 FLANGED	ARMSTRONG AVF
FE-PC-1	BLDG 101 MECH RM	PC	1.5 GPM	13 GPM	16 GPM	1-1/2"	1"	30	75	160	250	ULTRASONIC	THREADED	ONICON F-4600
FE-CHW-1	BLDG 101 MECH RM	CHW	50 GPM	400 GPM	650 GPM	6"	4"	30	150	42	65	ELECTROMAGNETIC	INSERTION	ONICON F-3500 WITH SYSTEM -10 BTU

THIS WOULD BE CONSIDERED A "NORMAL MAXIMUM CONDITION". FOR PC SERVICE, MAKE SURE THIS CONSIDERS ACTUAL PUMP FLOW RATE IF APPLICABLE

THIS IS THE PEAK UPSET CONDITION. FOR PC SERVICE, THIS COULD BE 2 PUMPS RUNNING

REDUCE DOWN PER FLOW METER RANGE

FROM PIPE SPEC

PER METER DETAILS

DETAIL STM-9 – SCHEDULE – FLOW METERS

REV 0, 05/29/18



USE THIS DESIGNATION FOR TRAPS. START AT "01" IN EACH MH. SEE LABELLING DESCRIPTION FOR TUNNELS.

LIST WHERE TRAP IS SHOWN IN SCHEMATIC

STEAM TRAP SCHEDULE															
STEAM TRAP DESIGNATION	GENERAL LOCATION DESCRIPTION	TYPE	CONN. SIZE	CONN. TYPE	PRESSURE (PSIG)		STEAM TEMP (DEG F)		DIFFERENTIAL PRESS. (PSID)		FLOW RATE (LB/HR)			DWG NO.	REMARKS
					OPER	DESIGN	OPER	DESIGN	OPER	DESIGN	OPER FLOW	SAFETY FACTOR	DESIGN FLOW		
STP-01	ON 8" 70S IN MH-3C3-3 TO BLDG 446	THERMOSTATIC	3/4"	THREADED	70	90	335	474	40	35	100	3	300	M5.01	WATSON & MCDANIELS WT2000

LIST PIPE SIZE, SELECTION, SERVICE, AND LOCATION

ALWAYS THERMOSTATIC IN DISTRIBUTION

LIST TRAP SIZES

ALWAYS THREADED

FOR OPERATING CONDITIONS, ASSUME PC MAIN PRESSURE IS 30 PSIG

FOR DESIGN CONDITIONS, ASSUME PC MAIN PRESSURE IS 45 PSIG. THIS DIFF IS BETWEEN OPERATING AND 45 PSIG AND SHALL BE THE BASIS FOR THE TRAP SELECTION

USE SAFETY FACTOR OF 3 FOR DISTRIBUTION

DO NOT CHANGE BASIS OF DESIGN

DETAIL STM-10 - SCHEDULE - STEAM TRAPS

REV 0, 05/29/18



SUMP PUMP SCHEDULE - STEAM POWERED

SUMP PUMP DESIGNATION	SUMP PUMP LOCATION	DESIGN HEAD (FT H ₂ O)	DESIGN FLOW (GPM)	DISCHARGE CONN. SIZE (NPS)	INLET STEAM CONDITIONS		MAX WATER TEMP (F)	BASIS OF DESIGN
					NORMAL PRESSURE (PSIG)	MAX PRESSURE (PSIG)		
SP-1	MH-3C3-3	5	31.2	1-1/2"	70	90	140	ARMSTRONG PUMP EJECTOR
SP-2	MH-3C3-11	5	31.2	1-1/2"	70	90	140	ARMSTRONG PUMP EJECTOR

LIST LOCATION OF SUMP PUMP

VERIFY FLOW REQUIREMENTS WITH FACILITIES SERVICES

VERIFY MAX WATER TEMP RESTRICTIONS WITH PUMP MANUFACTURER

USE THIS DESIGNATION FOR SUMP PUMPS. START AT "1" IN EACH MH.

CALCULATE REQUIREMENTS FOR EACH APPLICATION

SUMP PUMP SCHEDULE - ELECTRIC POWERED

SUMP PUMP DESIGNATION	SUMP PUMP LOCATION	DESIGN HEAD (FT H ₂ O)	DESIGN FLOW (GPM)	DISCHARGE CONN. SIZE (NPS)	MAXIMUM RPM	ELECTRICAL				BASIS OF DESIGN	REMARKS
						VOLTAGE	PHASE	HZ	HP		
SP-1	MH-3C1-1	20	23	1-1/2"	1750	230	1	60	0.50	ZOELLER D3098	
SP-2	MH-3C1-1	20	23	1-1/2"	1750	230	1	60	0.50	ZOELLER D3098	

LIST LOCATION OF SUMP PUMP

VERIFY FLOW REQUIREMENTS WITH FACILITIES SERVICES

VERIFY ELECTRICAL SERVICE AND HP

USE THIS DESIGNATION FOR SUMP PUMPS. START AT "1" IN EACH MH.

CALCULATE REQUIREMENTS FOR EACH APPLICATION

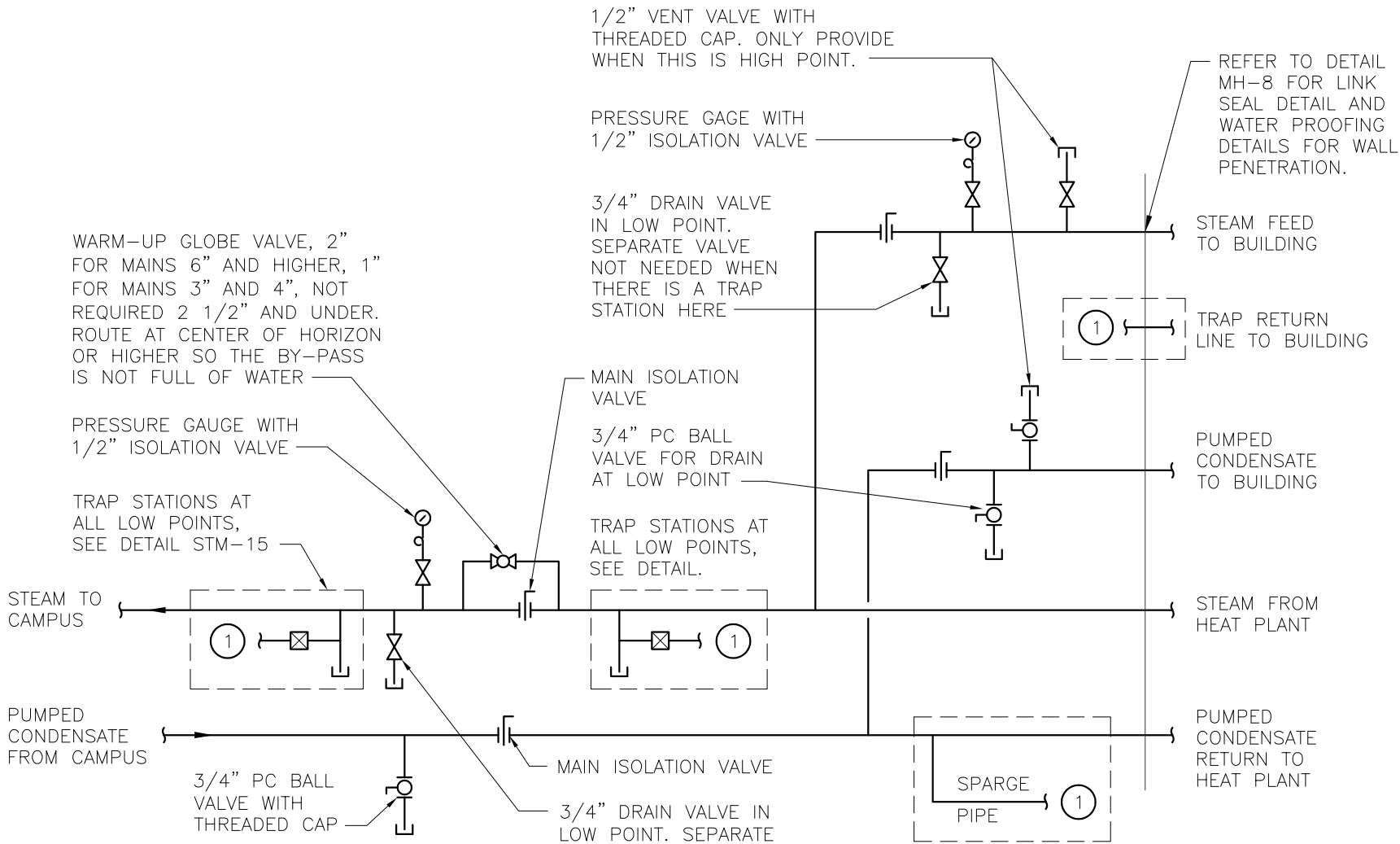

DETAIL NOTES:

1. PROVIDE INSULATION BLANKETS ON ALL FLANGED VALVES PER DETAIL.

DRAWING NOTES:

- ① FOR EXISTING MANHOLES TO BE REFURBISHED, DIRECT TRAP CONDENSATE INTO PUMPED RETURN LINE. FOR NEW MANHOLES, CREATE NEW TRAP RETURN MAIN AND SEND TO FLASH TANK IN BUILDING.

DETAIL STM-12 – STEAM & CONDENSATE MANHOLE ISOLATION VALVES – ONE-DIRECTIONAL BRANCH FLOW

REV 1, 03/29/19



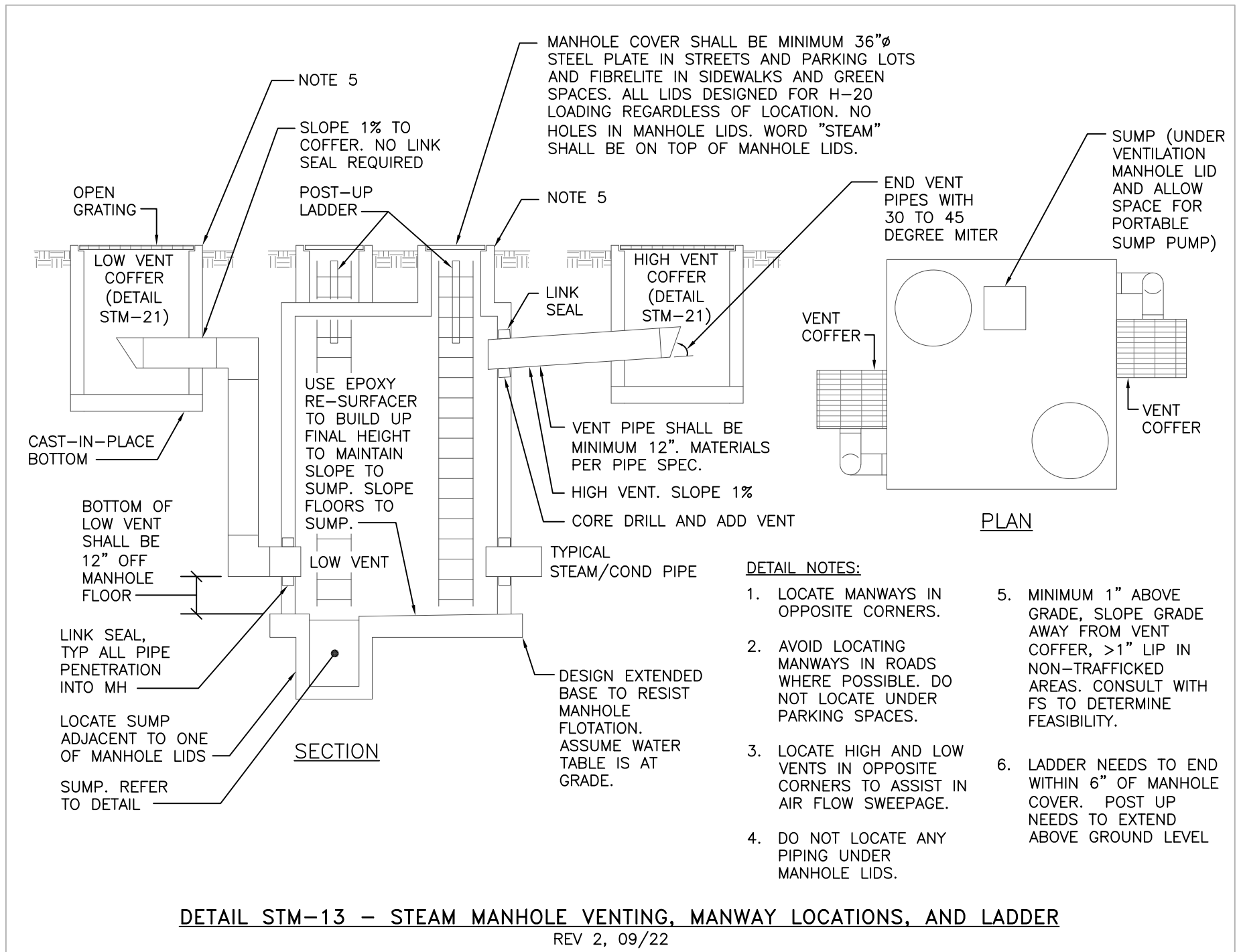

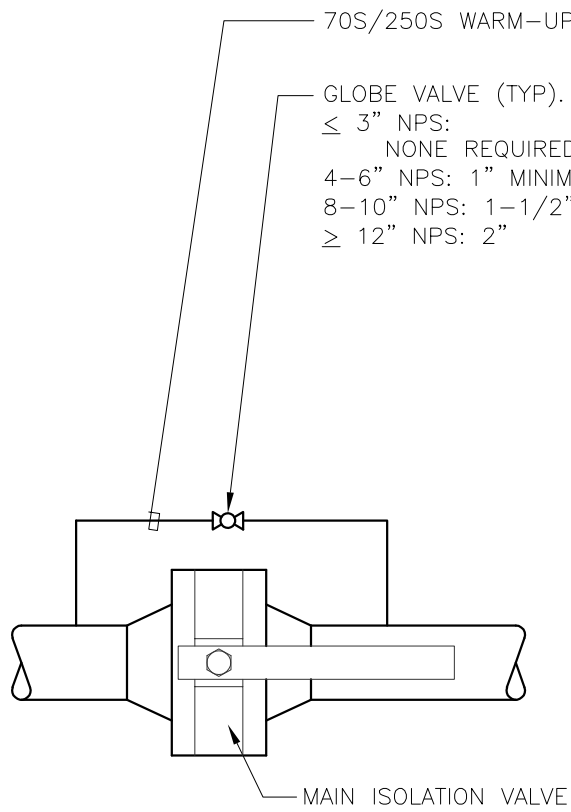

HORIZONTAL PIPE

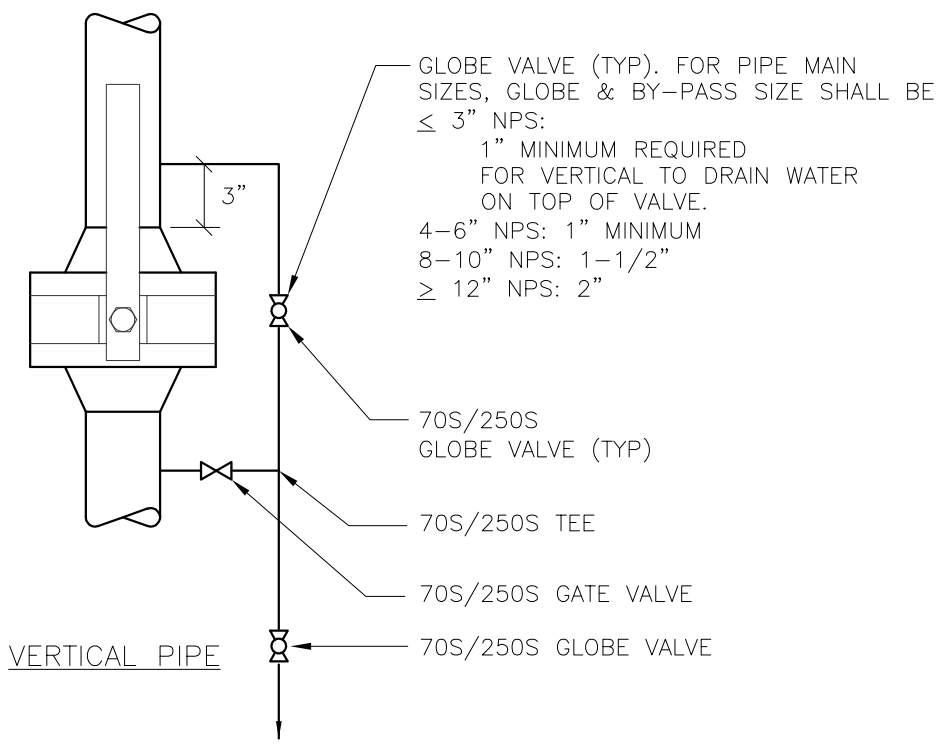

VERTICAL PIPE

DETAIL STM-14 - STEAM SYSTEM WARM-UP VALVE

REV 0, 5/29/18

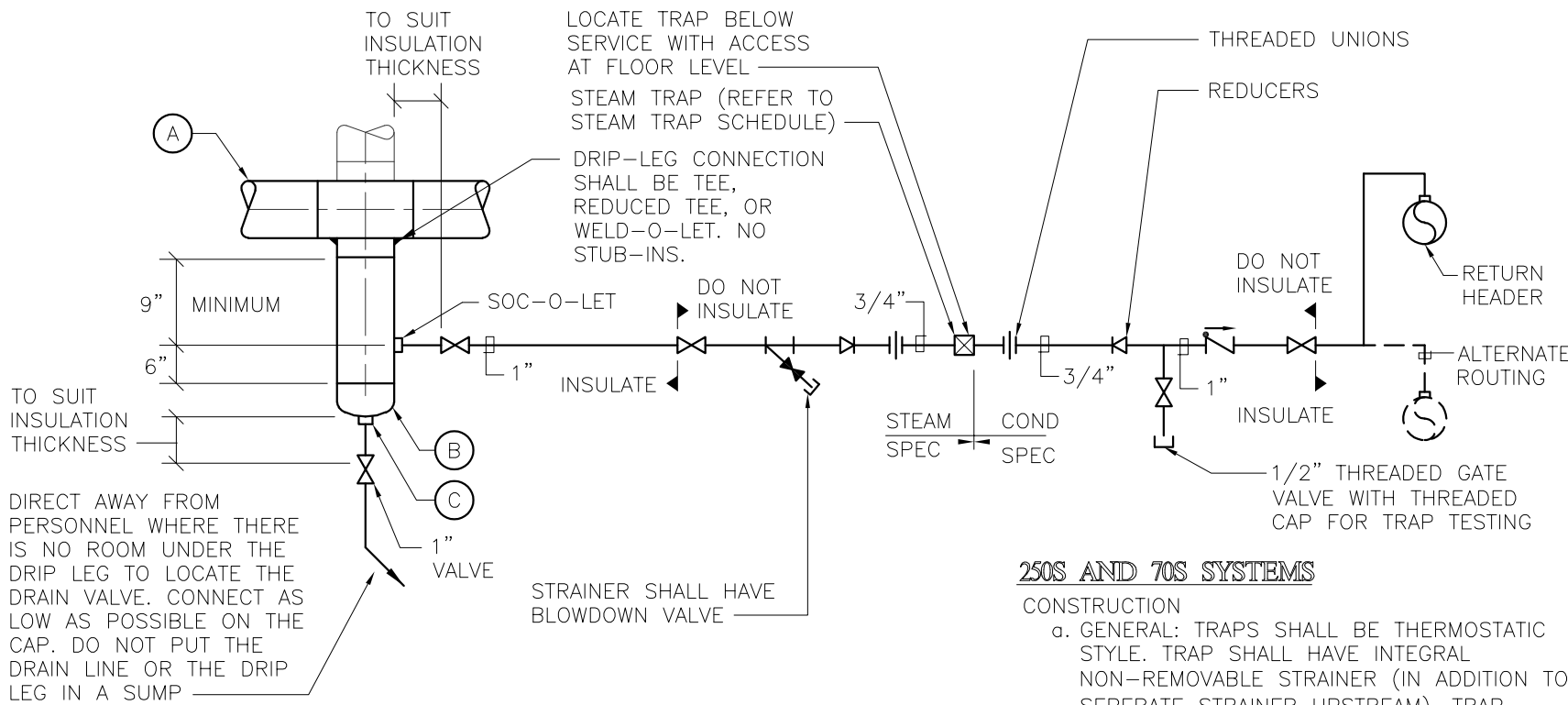

250S AND 70S SYSTEMS

CONSTRUCTION

- a. GENERAL: TRAPS SHALL BE THERMOSTATIC STYLE. TRAP SHALL HAVE INTEGRAL NON-REMOVABLE STRAINER (IN ADDITION TO SEPERATE STRAINER UPSTREAM). TRAP SHALL HAVE STAINLESS STEEL THERMAL ELEMENT THAT RESISTS SHOCK FROM WATER HAMMER. TRAP SHALL BE NON-REPAIRABLE. ALL COMPONENTS SHALL BE DESIGNED FOR MAXIMUM ALLOWABLE STEAM CONDITIONS OF 650 PSIG AT SATURATED TEMPERATURE.
- b. BODY: STAINLESS STEEL, ASTM A351-CF3.
- c. THERMAL ELEMENT: STAINLESS STEEL.
- d. VALVE AND SEAT: STAINLESS STEEL, AISI 416
- e. STRAINER SCREEN: STAINLESS STEEL
- f. ACCEPTABLE MANUFACTURERS: WATSON MCDANIEL MODEL WT2000. PROVIDE 3/4" TRAP BODY SIZE. ORIFICE SIZE SHALL BE SELECTED BY ENGINEER FOR CONDENSATE LOAD. THE UNIVERSITY STOCKS THIS MODEL SO DO NOT SUBMIT ANY OTHER MANUFACTURER/MODEL.

(A) SERVICE PIPE SIZE (NPS)	(B) DRIP-LEG SIZE (NPS)	(C) DRAIN CONNECTION
2" & SMALLER	FULL SIZE	FULL SIZE PIPE W/ REDUCING COUPLING
2 1/2" - 4"	FULL SIZE	FULL SIZE PIPE CAP W/ 1" SOC-O-LET
6"-8"	4"	FULL SIZE PIPE CAP W/ 1" SOC-O-LET
10"-12"	6"	FULL SIZE PIPE CAP W/ 1" SOC-O-LET
14"-16"	8"	FULL SIZE PIPE CAP W/ 1" SOC-O-LET

DETAIL NOTES:

1. SCHEDULE ALL STEAM TRAPS. DO NOT LEAVE UP TO CONTRACTOR TO SIZE TRAPS.
2. ALL SHUT-OFF (ISOLATION) VALVES ASSOCIATED WITH THE STEAM TRAP STATION SHALL BE THREADED.

DETAIL STM-15 – STEAM TRAP STATION AND DRIP-LEG CONFIGURATION

REV 2, 03/29/19



DETAIL NOTES:

1. EXPANSION LOOPS ARE PREFERRED OVER EXPANSION JOINTS. IN LOCATIONS ALLOWED BY FACILITIES SERVICES, PROVIDE EXTERNALLY PRESSURIZED EXPANSION JOINTS PER THE DESIGN STANDARDS.
2. WHEN USING EXPANSION JOINTS, ANCHORS SHALL BE AT ELBOWS WHERE THERE ARE CHANGES IN DIRECTIONS, NOT IN STRAIGHT RUNS.
3. EXPANSION JOINTS IN PIPE SIZES 6" AND LARGER SHALL BE PROVIDED WITH SUPPORT BASES. DO NOT BOLT BASES DOWN OR USE AS PIPE ANCHORS. PROVIDE SEPARATE ANCHOR.
4. LOCATE STEAM DRIP LEGS IN THE PIPES ON THE ANCHOR SIDE OF THE EXPANSION JOINTS.
5. CONNECT TRAP DISCHARGE INTO PC MAINS ON ANCHORED SIDES OF EXPANSION JOINTS.
6. DO NOT PERMANENTLY SUPPORT EXPANSION JOINTS BY LIFTING LUGS.
7. SUPPORT OF PIPING FROM CEILING OF MANHOLES OR TUNNELS SHALL BE LIMITED TO LOADS OF 100 LBS OR LESS.
8. ALL FLOOR MOUNTED SUPPORTS, ANCHORS, ETC. SHALL BE ON 2" MIN GROUT PADS.

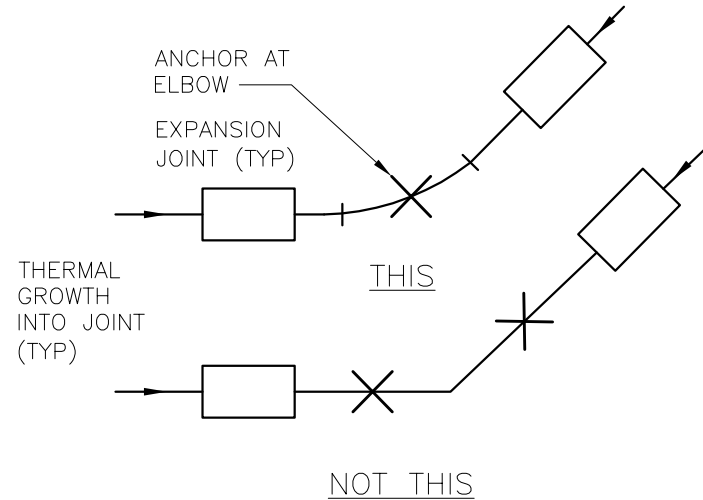

LEAVE MOVING END UN-INSULATED FOR THE RATED MOVEMENT OF THE JOINT

PROVIDE GUIDE IN MANHOLE REGARDLESS OF ANY OTHER DIRECTION. LINK SEALS ARE NOT GUIDES.

AT MANHOLE WALL, DOUBLE WALL DIRECT BURIED SYSTEMS SHALL HAVE GLAND SEALS WHEN CONNECTED TO PIPE INTO SLIDING SIDE OF AN EXPANSION JOINT

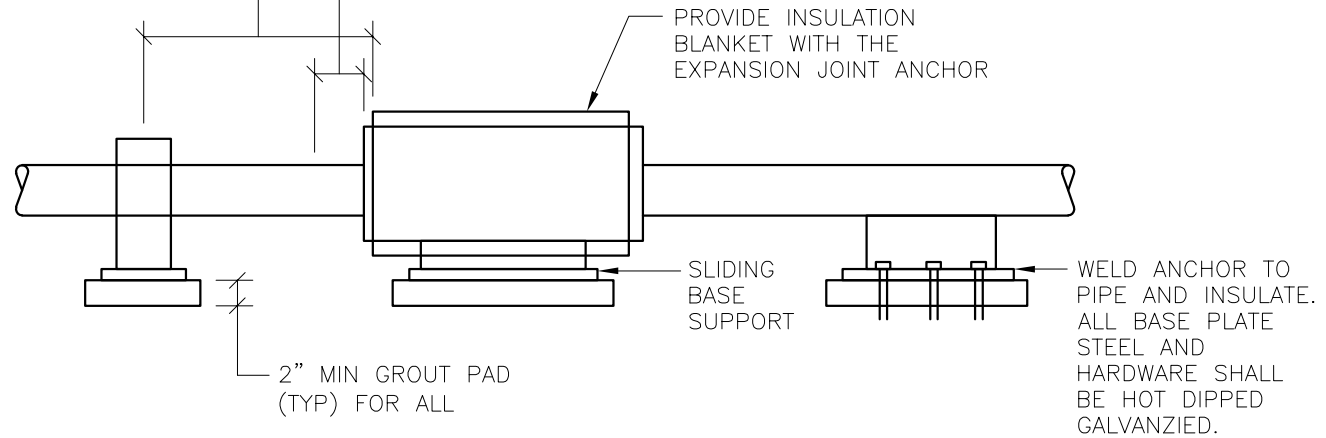

DETAIL STM-16 – STEAM AND CONDENSATE ANCHORS, GUIDES, & EXPANSION JOINTS

REV 1, 03/29/19

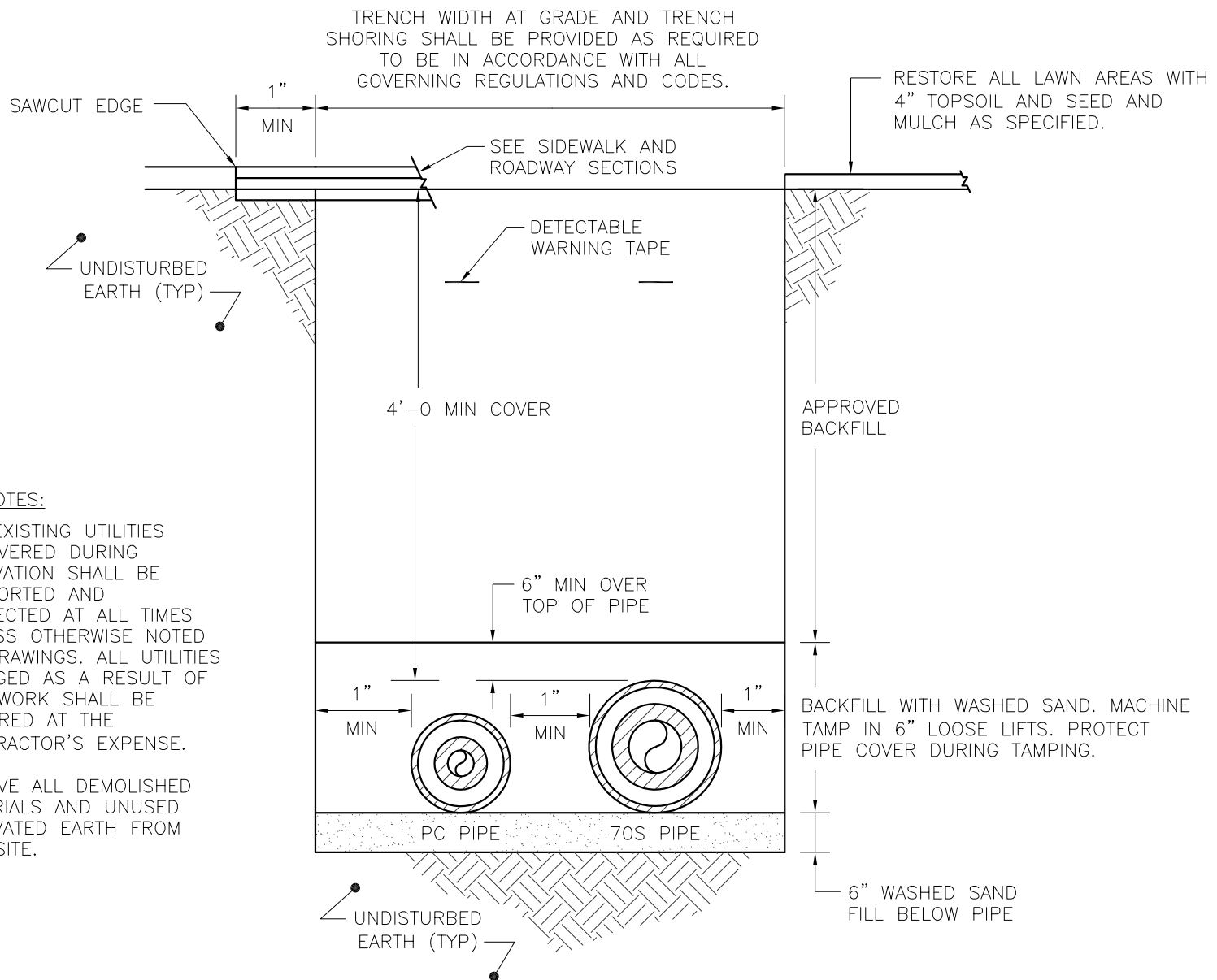

DETAIL NOTES:

1. ALL EXISTING UTILITIES UNCOVERED DURING EXCAVATION SHALL BE SUPPORTED AND PROTECTED AT ALL TIMES UNLESS OTHERWISE NOTED ON DRAWINGS. ALL UTILITIES DAMAGED AS A RESULT OF NEW WORK SHALL BE REPAIRED AT THE CONTRACTOR'S EXPENSE.
2. REMOVE ALL DEMOLISHED MATERIALS AND UNUSED EXCAVATED EARTH FROM THE SITE.

DETAIL STM-17 - STEAM & CONDENSATE DIRECT BURIED SYSTEM UTILITY TRENCH SECTION

REV 0, 5/29/18

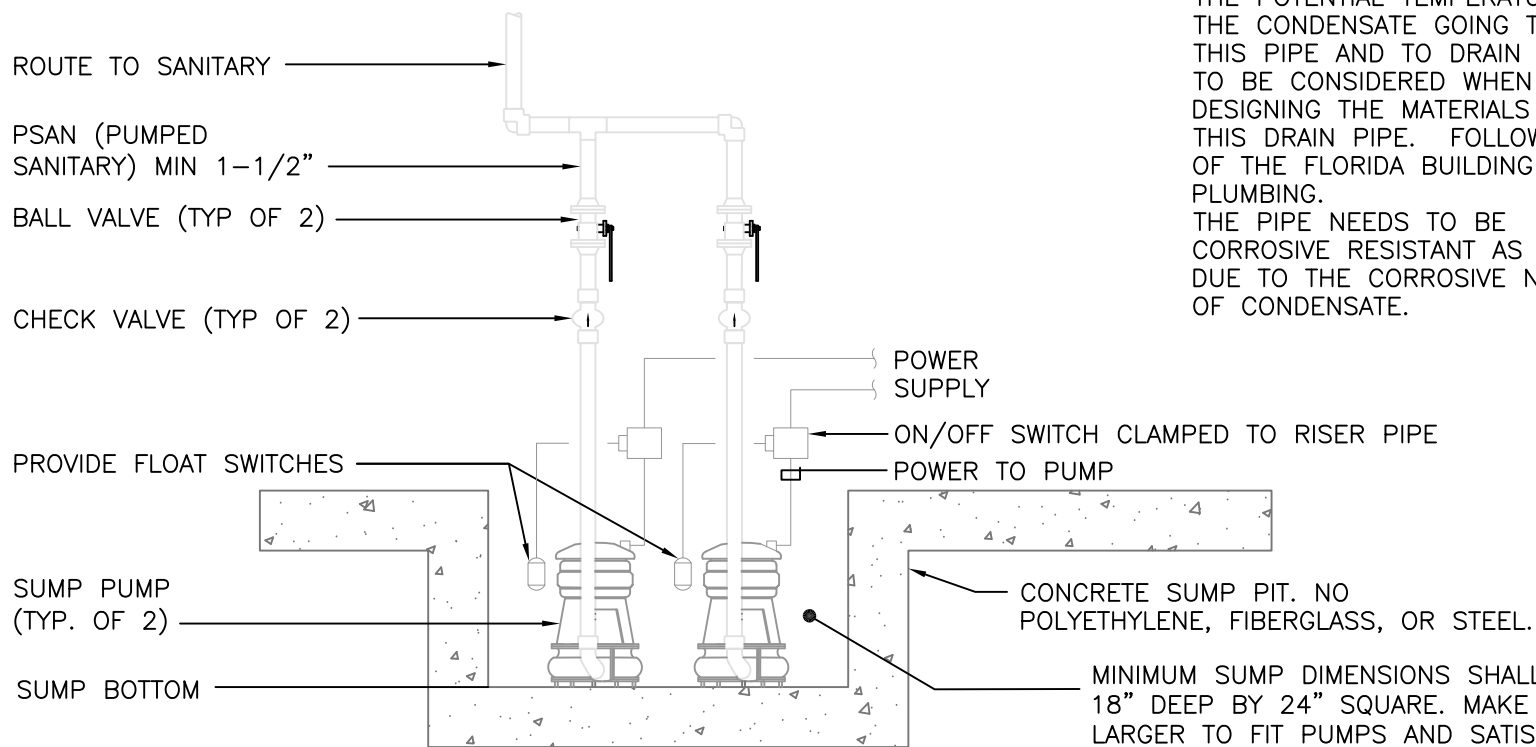

PSAN NOTES:
 THE POTENTIAL TEMPERATURE OF THE CONDENSATE GOING THROUGH THIS PIPE AND TO DRAIN NEEDS TO BE CONSIDERED WHEN DESIGNING THE MATERIALS FOR THIS DRAIN PIPE. FOLLOW 702.5 OF THE FLORIDA BUILDING CODE, PLUMBING.
 THE PIPE NEEDS TO BE CORROSIVE RESISTANT AS WELL DUE TO THE CORROSIVE NATURE OF CONDENSATE.

SIDE VIEW

DETAIL NOTES:

1. ELECTRIC POWERED SUMP PUMPS ARE NOT PREFERRED FOR STEAM MANHOLES. THEY ARE ONLY ALLOWED WITH WRITTEN PERMISSION FROM UF FACILITIES SERVICES
2. ELECTRICAL CONDUIT SHALL BE ALUMINUM.
3. PROVIDE FEMALE PIGTAIL TO POWER THE PUMP, NOT A RECEPTACLE.
4. PUMP CAPACITY SHALL BE MINIMUM 25 GPM AND POSSIBLY HIGHER PER FACILITIES HEAD SHALL BE CALCULATED BY ENGINEER CONSIDERING BOTH PUMPS RUNNING AT DESIGN LOAD.
5. PUMP SHALL BE ZOELLER 3000 HIGH-TEMPERATURE SERIES (SUCH AS MODEL D3137) RATED FOR 200°F CONTINUOUS SERVICE, 1/2" SOLIDS, PROVIDED WITH FLOAT FOR EACH PUMP MOUNTED ABOVE OPERATING LEVEL ON PUMP DISCHARGE PIPE.
6. PREFERRED TO HAVE 1/2 HP, 1 PH, 120V SERVICE BUT MAY BE 1/2 HP, 1 PH, 230V SERVICE TO ACCOMMODATE LONG POWER RUNS.

DETAIL STM-18 – SUMP PUMP – ELECTRIC POWERED

REV 1, 09/2022

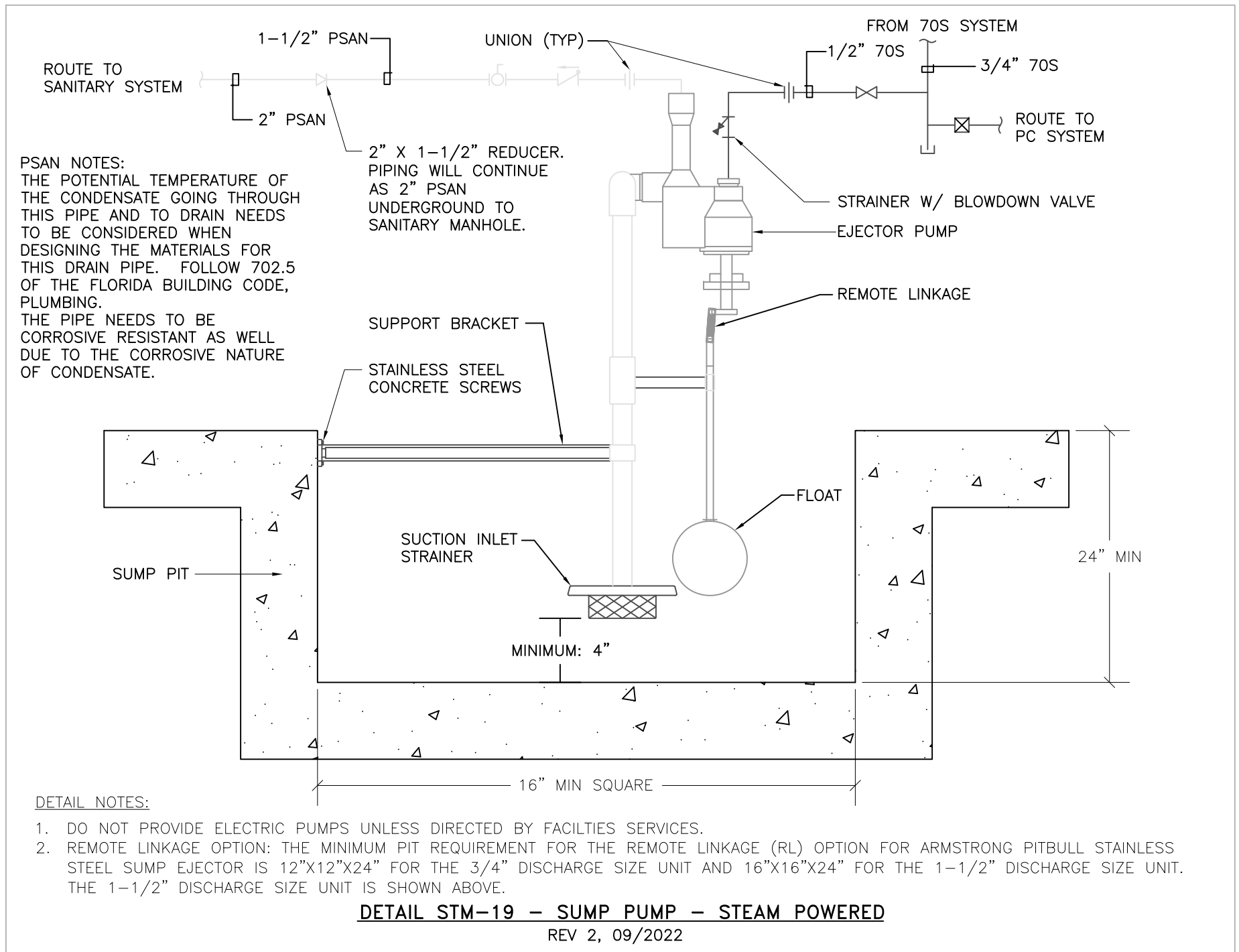

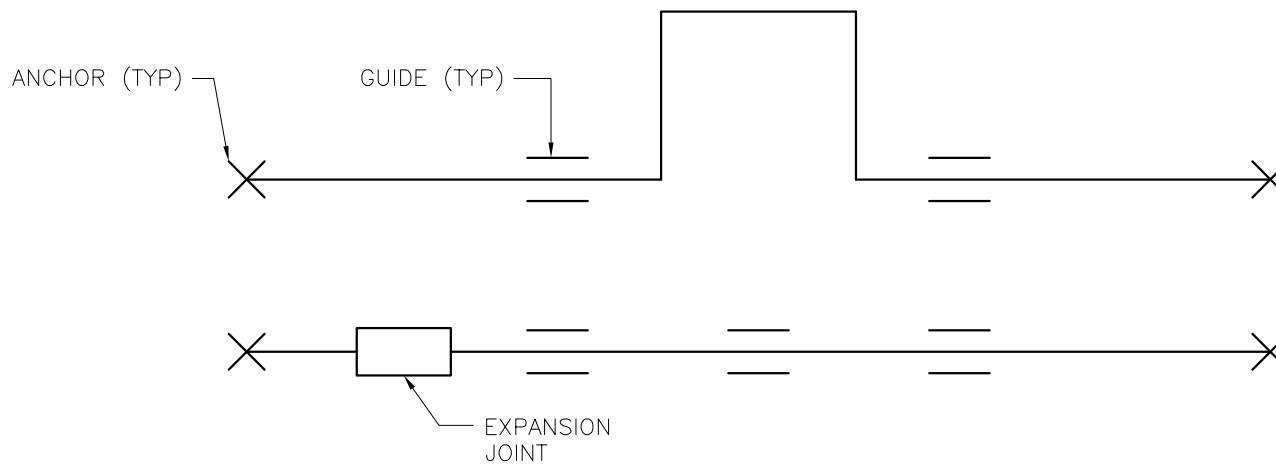

DETAIL NOTES:

1. SUBMIT THERMAL STRESS ANALYSIS FOR APPROVAL BY FACILITIES SERVICES FOR PROPOSED LAYOUT IN CONFORMANCE WITH ASME B31.1. THERMAL STRESS ANALYSIS IS ALSO REQUIRED FOR DIRECT BURIED PIPE SYSTEMS DURING DESIGN BY THE ENGINEER TO PROVE PROPOSED LAYOUT IS CODE COMPLIANT. USE DESIGN PRESSURE AND TEMPERATURE PER PIPING INDEX. ANALYSIS SHALL BE SIGNED AND SEALED BY A LICENSED PROFESSIONAL ENGINEER IN THE STATE OF FLORIDA.
2. EXPANSION LOOPS ARE PREFERRED.
3. ANCHORS SHALL BE GPS LOCATED DURING CONSTRUCTION EITHER BY UF OR ITS PROXY.

DETAIL STM-20 – THERMAL STRESS REQUIREMENTS

REV 0, 5/29/18

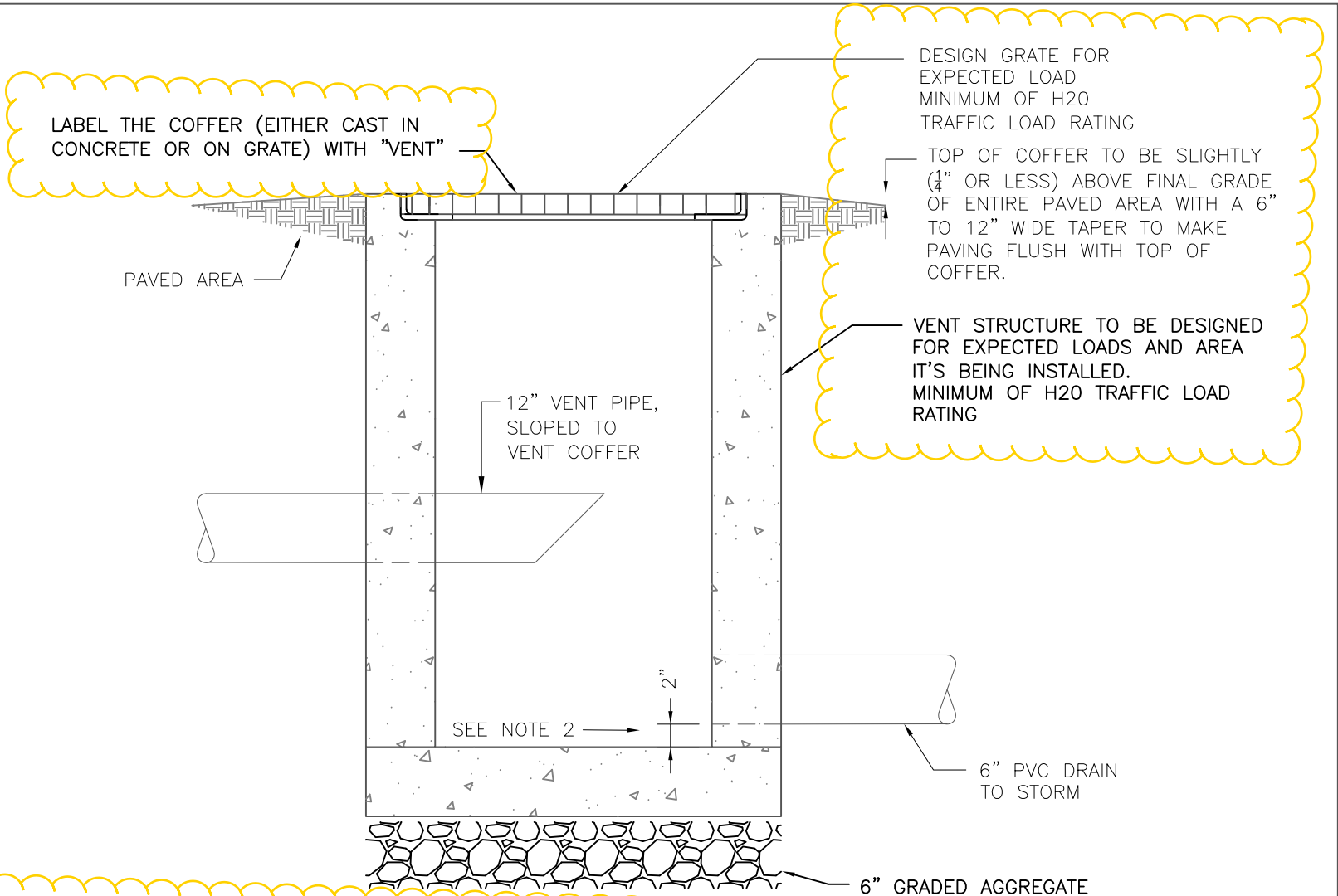

DETAIL NOTES:

1. REASONABLE EFFORT SHOULD BE MADE TO KEEP COFFER VENTS OUT OF PAVED AREAS.
2. THE PENETRATIONS OF ALL PIPES INTO AND OUT OF VENT COFFERS SHALL BE SEALED WITH NON SHRINKING GROUT. THE USE OF BRICKS FOR FILLING LARGE GAPS IS NOT ALLOWED.
3. FIELD FORM CONCRETE CHANNEL IN BOTTOM 2" OF VENT COFFER WITH PORTLAND CEMENT DESIGN MIX, 4000 PSI MINIMUM, WITH 0.45 WATER/CEMENTITIOUS MATERIALS.
4. VENT SHALL BE PLACED IN LOCATIONS THAT WILL REDUCE THE POTENTIAL FOR STORM WATER TO FLOW INTO THEM. (I.E. HIGH SPOT IN PARKING LOTS, CENTER OF LANES FOR ROADWAYS)

DETAIL STM-21 – VENT COFFER FOR PAVED AREAS

REV 3, 03/2024

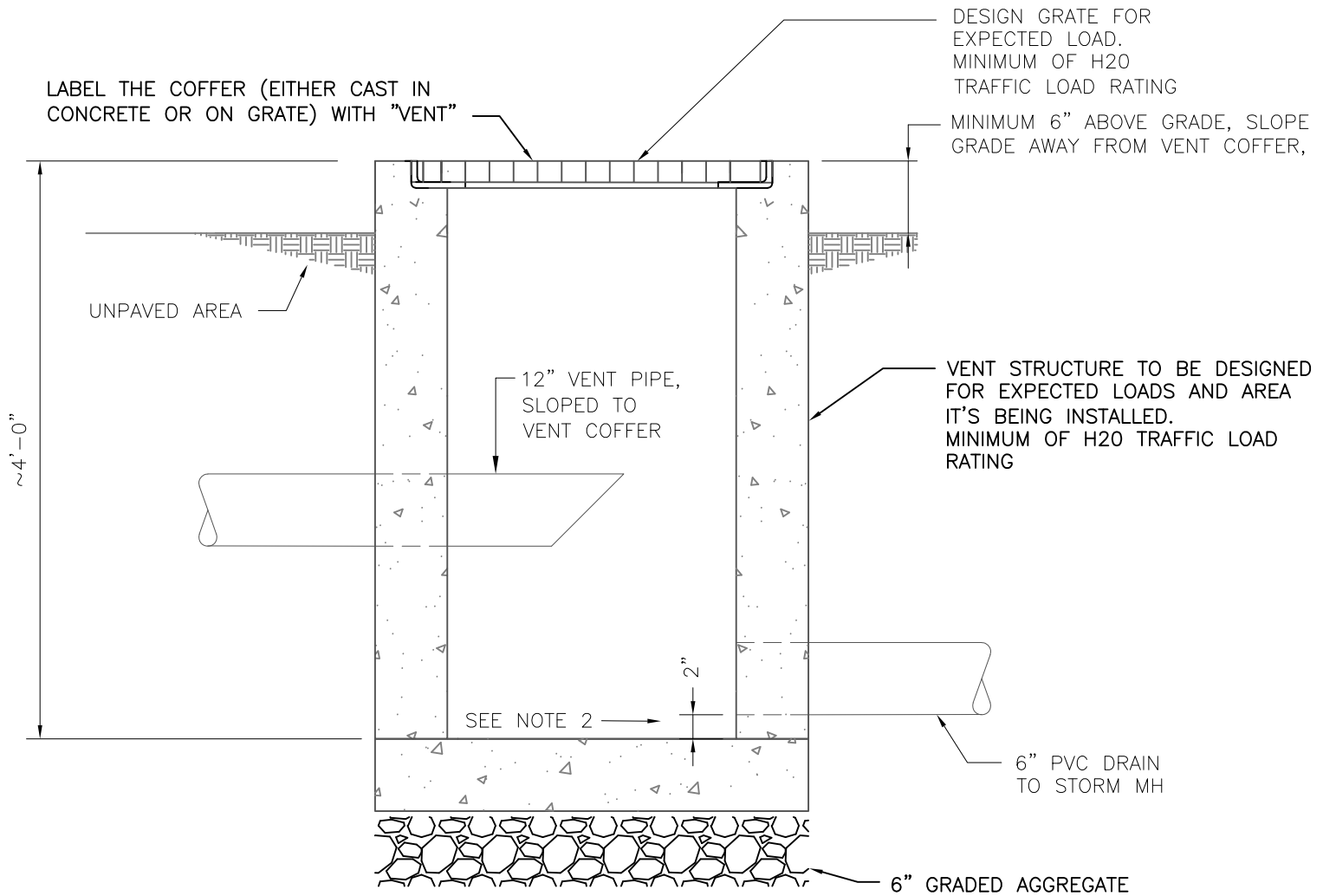

DETAIL NOTES:

1. THE PENETRATIONS OF ALL PIPES INTO AND OUT OF VENT COFFERS SHALL BE SEALED WITH NON SHRINKING GROUT. THE USE OF BRICKS FOR FILLING LARGE GAPS IS NOT ALLOWED.
2. FIELD FORM CONCRETE CHANNEL IN BOTTOM 2" OF VENT COFFER WITH PORTLAND CEMENT DESIGN MIX, 4000 PSI MINIMUM, WITH 0.45 WATER/CEMENTITIOUS MATERIALS.

DETAIL STM-22 – VENT COFFER FOR UNPAVED AREAS

REV 1, 02/2023